



INSTYTUT TECHNIKI BUDOWLANEJ
 PL 00-611 WARSZAWA
 ul. Filtrowa 1
 tel.: (+48 22) 825-04-71
 (+48 22) 825-76-55
 fax: (+48 22) 825-52-86
www.itb.pl



European Technical Assessment

**ETA-17/1062
 of 17/09/2020**

General Part

Technical Assessment Body issuing the European Technical Assessment

Instytut Techniki Budowlanej

Trade name of the construction product

PiroCoating
 PiroCoat I
 PiroCoat A

Product family to which the construction product belongs

Fire Stopping and Fire Sealing Products.
 Penetration Seals

Manufacturer

PIROSYSTEM Sp. z o.o.
 ul. Ogrodniczna 3A
 PL 83-021 Wiślina
 Poland

Manufacturing plant

Manufacturing plant no. 1

This European Technical Assessment contains

95 pages including 3 Annexes which form an integral part of this Assessment

This European Technical Assessment is issued in accordance with regulation (EU) No 305/2011, on the basis of

European Assessment Document (EAD) 350454-00-1104 "Fire Stopping and Fire Sealing Products. Penetration Seals"

This version replaces

ETA-17/1062 issued on 14/12/2017

This European Technical Assessment is issued by the Technical Assessment Body in its official language. Translations of this European Technical Assessment in other languages shall fully correspond to the original issued document and shall be identified as such.

Communication of this European Technical Assessment, including transmission by electronic means, shall be in full. However, partial reproduction may only be made with the written consent of the issuing Technical Assessment Body. Any partial reproduction has to be identified as such.

Specific Part

1 Technical description of the product

The PiroCoating is a white colour intumescent coating paint. The PiroCoat I is a grey colour intumescent sealant. The PiroCoat A is an ablative acrylic sealant. These products are used to form single or mixed penetration seals where combustible or metal pipes (insulated and non-insulated) and cables penetrate walls and floors.

Auxiliary products used with PiroCoating, PiroCoat I and PiroCoat A to form penetration seals are:

- synthetic, flexible elastomeric foam (FEF) in accordance with EN 14304 with reaction to fire class B_L-s3,d0, according to EN 13501-1, and with an apparent density of 45 – 70 kg/m³,
- PE foam insulation of nominal density of 30 kg/m³ and reaction to fire class E in accordance with EN 13501-1,
- Piro Multitube PM in accordance with ETA-17/1061,
- Piro Collar PC in accordance with ETA-17/1063,
- mineral wool (MW) in accordance with EN 13162 and Annexes B and C.

2 Specification of the intended use in accordance with the applicable European Assessment Document (EAD)

2.1 Intended use

The intended use of PiroCoating, PiroCoat I and PiroCoat A is to reinstate the fire resistance performance of flexible wall, rigid wall or rigid floor constructions, where they are penetrated by combustible or metal pipes (insulated and non-insulated) and cables.

The specific elements of construction that PiroCoating, PiroCoat I and PiroCoat A may be used to provide a penetration seal in, are as follows:

Rigid walls: The wall must have a minimum thickness of 100, 125 or 150 mm (for details see Annex B) and comprise concrete, reinforced concrete, aerated concrete, ceramic brick, cavity brick or checker brick, with a minimum density of 600 kg/m³.

Flexible walls: The wall must have a minimum thickness of 100 or 125 mm and comprise timber or steel studs lined on both faces with minimum two layers (with overall board layer thickness on one side equal to or greater than 25 mm) of 'Type F' or 'Type DF' gypsum plasterboards according to EN 520. In timber stud walls, no part of the penetration shall be closer than 100 mm to a stud, the cavity must be closed between the penetration seal and the stud and minimum 100 mm of insulation of reaction to fire class A1 or A2, according to EN 13501-1, is provided within the cavity between the penetration seal and the stud.

Rigid floors: The floor must have a minimum thickness of 150 mm and comprise concrete, reinforced concrete, with a minimum density of 1700 kg/m³.

The supporting construction shall be classified in accordance with EN 13501-2 for the required fire resistance period (equal to or greater than specified in Annex B).

PiroCoating, PiroCoat I and PiroCoat A may be used to provide a penetration seal with specific combustible and metal pipes and cables (according to Annex B).

Details of penetration seals are provided in Annexes B and C. Additional provisions are provided in Annex A.

The performances given in this European Technical Assessment are based on an assumed working life of the product of 10 years. The indications given on the working life cannot be interpreted as a guarantee given by the producer or the Technical Assessment Body, but are to be regarded only as a means for choosing the right products in relation to the expected economically reasonable working life of the works.

2.2 Use category

Type Z₂: intended for use in internal conditions with humidity lower than 85% RH, excluding temperatures below 0°C, without exposure to rain or UV.

3 Performance of the product and references to the methods used for its assessment

3.1 Performance of the product

3.1.1 Safety in case of fire (BWR 2)

Essential characteristic	Performance
Reaction to fire	B-s2, d0
Resistance to fire	Annex B

3.1.2 Hygiene, health and the environment (BWR 3)

No performance assessed.

3.1.3 Safety and accessibility in use (BWR 4)

Essential characteristic	Performance
Durability	Use category: Type Z ₂

3.1.4 Protection against noise (BWR 5)

No performance assessed.

3.1.5 Energy economy and heat retention (BWR 6)

No performance assessed.

3.2 Methods used for the assessment

The assessment of the products has been made in accordance with the European Assessment Document EAD 350454-00-1104 “Fire Stopping and Fire Sealing Products. Penetration Seals”.

4 Assessment and verification of constancy of performance (AVCP) system applied, with reference to its legal base

According to Decision 99/454/EC of the European Commission, as amended by Decision 2001/596/EC of the European Commission the system 1 of assessment and verification of constancy of performance applies (see Annex V to Regulation (EU) No 305/2011).

5 Technical details necessary for the implementation of the AVCP system, as provided in the applicable European Assessment Document (EAD)

Technical details necessary for the implementation of the AVCP system are laid down in the control plan deposited in Instytut Techniki Budowlanej.

For type testing the results of the tests performed as part of the assessment for the European Technical Assessment shall be used unless there are changes in the production line or plant. In such cases the necessary type testing has to be agreed between Instytut Techniki Budowlanej and the notified body.

Issued in Warsaw on 17/09/2020 by Instytut Techniki Budowlanej



Anna Panek, MSc
Deputy Director of ITB

Additional provisions for single penetration seals:

- Classifications given in Annex B are valid for specific pipes made of
 - PVC-U according to EN 1329-1, EN 1453-1 or EN 1452-1,
 - PVC-C according to EN 1566-1,
 - PE according to EN 12201-2, EN 1519-1 and EN 12666-1,
 - PE-HD according to EN 1519-1 or EN 12666-1,
 - PP according to EN 1451-1,
 - ABS according to EN 1455-1,
 - SAN + PVC according to EN 1565-1,
 - PE-X according to EN ISO 21003-1, EN ISO 21003-2 and EN ISO 21003-3,
 - PP-R/AL/PP-R according to EN ISO 23391-2,
 - PP-R STABI AL according to EN ISO 21003-2,
 - PP-R/GF/PP-R according to EN ISO 15874,
 - PP-R/PP-R+GF/PP-R according to EN ISO 15874,
 - PE-RT/AL/PE-RT according to EN ISO 21003,
 - steel Spiro pipes,
according to tables in Annex B.
- Classifications given in Annexes B11 and B20 for “small cable” is valid for cable penetration seals of all cable types currently and commonly used in building practice in Europe to a maximum diameter of 21 mm, except tied bundles, waveguides and non-sheathed cables / wires (optical fibre cables are covered). The maximum dimensions of: a x b = 130 x 360 mm, in which the total amount of cross sections of the services (including insulation) does not exceed 60% of the penetration area.
- Classifications given in Annex B12 and B13 for “single small cables” is valid for cable penetration seals of single cable of all cable types currently and commonly used in building practice in Europe to a maximum diameter of given in the appropriate point, except tied bundles, waveguides and non-sheathed cables / wires (optical fiber cables are covered).
- Classifications given in Annex B11 and B20 for “small cables” is valid for the cable supports pass through the seal and for those situations where the cable supports does not pass through the seal.
- Classifications given in Annex B11 and B20 for “small cables” is not valid for lidded cable trays/trunkings where the lid passes through the penetration seal.
- Classifications given in Annex B24 and B25 for “small cables” is valid for cables with maximum diameter of 14 mm, following types: NYY-J 5x1,5 RE, E-YY-J 5x1,5 RE or VV 5x1,5.
- Classifications given in Annex B for “steel pipes type Geberit N” is valid for thinwalled stainless steel pipes according to EN 10305-3.
- Classifications given in Annex B for steel and copper pipes are also valid for other metal pipes with:
 - thermal conductivity lower than respectively steel or copper, and
 - melting point at least equal to respectively steel or copper, and greater than:
 - 739 °C for the fire resistance class EI 15 and E 15,
 - 782 °C for the fire resistance class EI 20 and E 20,
 - 843 °C for the fire resistance class EI 30 and E 30,
 - 903 °C for the fire resistance class EI 45 and E 45,
 - 946 °C for the fire resistance class EI 60 and E 60,
 - 1006 °C for the fire resistance class EI 90 and E 90,
 - 1049 °C for the fire resistance class EI 120 and E 120.

PiroCoating, PiroCoat I and PiroCoat A	Annex A of European Technical Assessment ETA-17/1062
Additional provisions	

- Classifications given in Annex B for cast iron pipes are also valid for other metal pipes with:
 - thermal conductivity lower than respectively cast iron, and
 - melting point at least equal to respectively cast iron, and greater than:
 - 739 °C for the fire resistance class EI 15 and E 15,
 - 782 °C for the fire resistance class EI 20 and E 20,
 - 843 °C for the fire resistance class EI 30 and E 30,
 - 903 °C for the fire resistance class EI 45 and E 45,
 - 946 °C for the fire resistance class EI 60 and E 60,
 - 1006 °C for the fire resistance class EI 90 and E 90,
 - 1049 °C for the fire resistance class EI 120 and E 120.
- The minimum distances in supporting construction shall be:
 - not restricted – between the adjacent insulations in the penetration seals in case of metal pipes with local or continuous mineral wool insulation (according to Annex B1 - B5, B14 - B17, B22),
 - 20 mm – between the pipes in the penetration seals in case of metal pipes bundle without insulation (according to Annex B23),
 - 20 mm – between the adjacent seals for bundle of two pipes with continuous PE foam insulation and “small cable” with maximum diameter of 14 mm – pipes and cable in bundle cling to each other (according to Annex B25),
 - 20 mm – between the adjacent pipes (pasta cover) in the penetration seals in case of metal pipes without insulation sealed with PiroCoat I and PiroCoat A (according to Annex B26),
 - 25 mm – between the adjacent pipes (pasta cover) in the penetration seals in case of metal pipes without insulation sealed with PiroCoat I (according to Annex B6 - B8, B18),
 - 30 mm – between the adjacent wraps in the penetration seals in case of metal pipes with PE foam continuous insulation or flexible elastomeric foam (FEF) continuous insulation (according to Annexes B10 and B13).
- The minimum distance between the adjacent penetration seals in supporting construction in case of plastic pipes and cables shall be 100 mm.
- Distance from the surface of separating element to the first place of pipes and cables support is max. 370 mm.
- Classifications given in Annex B for pipes with mineral wool insulation or mineral wool continuous insulation is valid for pipes with sustained and continuous insulation made of mineral wool (for details see clause 1 of ETA) and does not cover locally insulated or non-insulated pipes. Thickness and density may be increased but may not be reduced. In this case classification is valid for services placed in all angles between 90° and 45° to the supporting construction.
- Classifications given in Annex B for pipes with mineral wool local insulation is valid for pipes with local and continuous insulation made of mineral wool (for details see clause 1 and Annex B of ETA) and does not cover non-insulated pipes. Thickness and density may be increased but may not be reduced. In this case classification is valid for services placed in all angles between 90° and 45° to the supporting construction.
- Classifications given in Annex B for pipes with PE foam insulation and FEF foam insulation is valid for pipes with sustained and continuous insulation (for details see clause 1 and Annex B of ETA) and does not cover locally insulated or non-insulated pipes. The reaction to fire, density and thickness of insulation shall remain in accordance with ETA provisions. Length may be increased but may not be reduced.

PiroCoating, PiroCoat I and PiroCoat A	Annex A of European Technical Assessment ETA-17/1062
Additional provisions	

Additional provisions for mixed penetration seals:

- Classification given in Annex B27 – B35 covers mixed penetration seals.
- Classification given in table B29 and B30 is valid for pipes made from PE-HD according to EN 1519-1 or EN 12666-1, pipes made from PE according to EN 12201-2, EN 1519-1 and EN 12666-1, pipes made from ABS according to EN 1455-1 and pipes made from SAN + PVC according to EN 1565-1.
- Classification given in table B29 and B30 is valid for pipes made from PP according to EN 1451-1.
- Classification given in table B29 and B30 is valid for pipes made from PVC-U according to EN 1329-1, EN 1453-1 or EN 1452-1 and pipes made from PVC-C according to EN 1566-1.
- Classification given in tables B31 and B32 concerns local insulated pipes and does not cover non-insulated pipes. For penetrations classified in tables B31 and B32 the length, thickness and density of a local insulation may be increased but may not be reduced.
- Classification given in table B31 and B32 is valid for pipes with sustained and continuous insulation made of flexible elastomeric foam (FEF) in accordance with EN 14304, with reaction to fire class B_L-s3,d0, and does not cover non-insulated pipes. The reaction to fire, density and thickness of insulation shall remain in accordance with ETA provisions. Length may be increased but may not be reduced.
- Classification given in tables B31 and B32 for copper, steel and cast iron pipes is also valid for other metal pipes with thermal conductivity lower than respectively copper, steel and cast iron and a melting point at least equal to respectively copper, steel and cast iron and greater than:
 - 946 °C for the fire resistance class 60 minutes,
 - 1049 °C for the fire resistance class 120 minutes.
- Classification given in tables B30 and B31 is valid for pipes placed in all angles between 90° and 45° to the supporting construction.
- Classification given in Annex B27 and B28 covers:
 - all cable types currently and commonly used in building practice in EU with a diameter not greater than 80 mm; except waveguides; optical fibre cables are covered,
 - tied bundles with a diameter lower than 100 mm made of cables with diameter not greater than 21 mm,
 - all non-sheathed cables with diameter not greater than 24 mm,
 - all steel conduits and steel tubes with a diameter not greater than 16 mm (end configuration C/U, U/C and C/C),
 - all plastic conduits and plastic tubes with a diameter not greater than 16 mm (end configuration U/C and C/C).
- Classification given in Annex B27 and B28 is valid when cable supports pass through the seal and when cable supports don't pass through the seal.
- Classification given in Annex B11 is not valid for lidded cable trays/trunkings, when the lid passes through the penetration seal.
- Classification given in Annex B27 – B35 is valid for mixed penetration seals in which total amount of cross sections of services (including insulation) does not exceed 60% of the penetration area.
- The minimum distance between services in mixed penetration seals in supporting construction shall be as follows:
 - a) in walls the minimum distance:
 - between cables or cable trays and the lateral seal edge shall be 25 mm,
 - between cables and the upper seal edge shall be 0 mm,
 - between metal pipes with mineral wool insulation and seal edge shall be 25 mm,
 - between plastic pipes or metal pipes with flexible elastomeric foam (FEF) insulation and the seal edge shall be 30 mm – for pipes with collar pipe closure device,
 - between cable trays shall be 0 mm,
 - between cables and cable trays shall be 100 mm,
 - between metal pipes with mineral wool insulation shall be 30 mm,
 - between plastic pipes or metal pipes with flexible elastomeric foam (FEF) insulation shall be 0 mm – for pipes with collar pipe closure device,
 - between cables or cable trays and metal pipes with mineral wool insulation shall be 82 mm,

PiroCoating, PiroCoat I and PiroCoat A	Annex A of European Technical Assessment ETA-17/1062
Additional provisions	

- between cables or cable trays and plastic pipes or metal pipes with flexible elastomeric foam (FEF) insulation shall be 60 mm – for pipes with collar pipe closure device,
- between metal pipes with mineral wool insulation and plastic pipes or metal pipes with flexible elastomeric foam (FEF) insulation shall be 30 mm – for pipes with collar pipe closure device,
- b) in floors the minimum distance:
 - between cables or cable trays and the seal edge shall be 25 mm,
 - between metal pipes with mineral wool insulation and seal edge shall be 25 mm,
 - between metal pipes covered with PiroCoat I and seal edge shall be 25 mm,
 - between plastic pipes or metal pipes with flexible elastomeric foam (FEF) insulation and the seal edge shall be 30 mm – for pipes with collar pipe closure device,
 - between cable trays shall be 0 mm,
 - between cables and cable trays shall be 100 mm,
 - between metal pipes with mineral wool insulation shall be 30 mm,
 - between metal pipes covered with PiroCoat I shall be 100 mm,
 - between plastic pipes or metal pipes with flexible elastomeric foam (FEF) insulation shall be 0 mm – for pipes with collar pipe closure device,
 - between cables or cable trays and metal pipes with mineral wool insulation shall be 82 mm,
 - between cables or cable trays and metal pipes covered with PiroCoat I shall be 100 mm,
 - between cables or cable trays and plastic pipes or metal pipes with flexible elastomeric foam (FEF) insulation shall be 60 mm – for pipes with collar pipe closure device,
 - between metal pipes with mineral wool insulation and plastic pipes or metal pipes with flexible elastomeric foam (FEF) insulation shall be 30 mm – for pipes with collar pipe closure device,
 - between metal pipes with mineral wool insulation and metal pipes covered with PiroCoat I shall be 35 mm,
 - between metal pipes covered with PiroCoat I and plastic pipes or metal pipes with flexible elastomeric foam (FEF) insulation shall be 250 mm – for pipes with collar pipe closure device.
- Maximum dimensions of mixed penetration seals are (length x width):
 - 1200 x 1200 mm – for mixed penetration seal in wall,
 - 1500 x 1200 mm (or greater: increase of size of the penetration seal is permitted up to any length, as long as the perimeter length to seal area ratio is not smaller than 3/m) – for mixed penetration seal in floor.

PiroCoating, PiroCoat I and PiroCoat A	Annex A of European Technical Assessment ETA-17/1062
Additional provisions	

Table of contents:	
Annex B – Reaction to fire classification:	
Annex B1: Insulated metal pipes penetration seals in flexible wall	12
Annex B2: Insulated metal pipes penetration seals in rigid wall	13
Annex B3: Insulated metal pipes bundle penetration seals in flexible or rigid wall	15
Annex B4: Insulated metal pipes penetration seals in flexible or rigid wall	16
Annex B5: Insulated metal pipes penetration seals in rigid wall	19
Annex B6: Non-insulated metal pipes penetration seals in flexible wall	21
Annex B7: Non-insulated metal pipes penetration seals in rigid wall	22
Annex B8: Non-insulated metal or plastic pipes penetration seals in rigid wall	23
Annex B9: Insulated plastic pipes penetration seals in rigid wall	25
Annex B10: Insulated metal pipes penetration seals in rigid wall	26
Annex B11: Cables penetration seals in flexible or rigid wall	27
Annex B12: Cables penetration seals in flexible or rigid wall	28
Annex B13: Insulated metal pipes penetration seals in rigid wall	29
Annex B14: Insulated metal pipes penetration seals in rigid floor	30
Annex B15: Insulated metal pipes penetration seals in rigid floor	32
Annex B16: Insulated metal pipes penetration seals in rigid floor	33
Annex B17: Insulated metal pipes penetration seals in rigid floor	35
Annex B18: Non-insulated metal pipes penetration seals in rigid floor	36
Annex B19: Insulated plastic pipes penetration seals in rigid floor	39
Annex B20: Cables penetration seals in rigid floor	40
Annex B21: Insulated plastic pipes penetration seals in rigid floor	41
Annex B22: Insulated metal pipes penetration seals in rigid floor	42
Annex B23: Non-insulated metal pipes bundle penetration seals in rigid floor	43
Annex B24: Non-insulated plastic pipes bundle penetration seals in rigid floor	44
Annex B25: Insulated metal pipes penetration seals in rigid floor	45
Annex B26: Non-insulated metal pipes penetration seals in rigid floor	46
Annex B27: Cables in tray mixed penetration seals in rigid wall	47
Annex B28: Cables in tray mixed penetration seals in rigid floor	48
Annex B29: Insulated plastic pipes mixed penetration seals in rigid wall	49
Annex B30: Insulated plastic pipes mixed penetration seals in rigid wall	50
Annex B31: Insulated metal pipes mixed penetration seals in rigid wall	51
Annex B32: Insulated metal pipes mixed penetration seals in rigid floor	52
Annex B33: Insulated metal pipes mixed penetration seals in rigid wall	53
Annex B34: Insulated metal pipes mixed penetration seals in rigid floor	57
Annex B35: Non-insulated metal pipes mixed penetration seals in rigid floor	61
PiroCoating, PiroCoat I and PiroCoat A	Annex A of European Technical Assessment ETA-17/1062
Additional provisions	

Annex C – Construction details:	
Annex C1:	Insulated metal pipes penetration seals in flexible wall 62
Annex C2:	Insulated metal pipes penetration seals in rigid wall 63
Annex C3:	Insulated metal pipes bundle penetration seals in flexible or rigid wall 64
Annex C4:	Insulated metal pipes penetration seals in flexible or rigid wall 65
Annex C5:	Insulated metal pipes penetration seals in rigid wall 66
Annex C6:	Non-insulated metal pipes penetration seals in flexible wall 67
Annex C7:	Non-insulated metal pipes penetration seals in rigid wall 68
Annex C8:	Non-insulated metal or plastic pipes penetration seals in rigid wall 69
Annex C9:	Insulated metal pipes penetration seals in rigid wall 70
Annex C10:	Insulated metal pipes penetration seals in rigid wall 71
Annex C11:	Cables penetration seals in flexible or rigid wall 72
Annex C12:	Cables penetration seals in flexible or rigid wall 73
Annex C13:	Insulated metal pipes penetration seals in rigid floor 74
Annex C14:	Insulated metal pipes penetration seals in rigid floor 75
Annex C15:	Insulated metal pipes penetration seals in rigid floor 76
Annex C16:	Non-insulated metal pipes penetration seals in rigid floor 77
Annex C17:	Insulated plastic pipes penetration seals in rigid floor 78
Annex C18:	Cables penetration seals in rigid floor 79
Annex C19:	Insulated plastic pipes penetration seals in rigid floor 80
Annex C20:	Insulated metal pipes penetration seals in rigid floor 81
Annex C21:	Non-insulated metal pipes bundle penetration seals in rigid floor 82
Annex C22:	Non-insulated plastic pipes bundle penetration seals in rigid floor 83
Annex C23:	Insulated metal pipes penetration seals in rigid floor 84
Annex C24:	Non-insulated metal pipes penetration seals in rigid floor 85
Annex C25:	Mixed penetration seals 86
Annex C26:	Cables in tray mixed penetration seals in rigid wall 87
Annex C27:	Cables in tray mixed penetration seals in rigid floor 88
Annex C28:	Insulated plastic pipes mixed penetration seals in rigid wall 89
Annex C29:	Insulated plastic pipes mixed penetration seals in rigid floor 90
Annex C30:	Insulated metal pipes mixed penetration seals in rigid wall 91
Annex C31:	Insulated metal pipes mixed penetration seals in rigid floor 92
Annex C32:	Insulated metal pipes mixed penetration seals in rigid wall 93
Annex C33:	Insulated metal pipes mixed penetration seals in rigid floor 94
Annex C34:	Non-insulated Metal pipes mixed penetration seals in rigid floor 95
PiroCoating, PiroCoat I and PiroCoat A	
Additional provisions	Annex A of European Technical Assessment ETA-17/1062

Table B1. Resistance to fire classification of metal pipes with continuous mineral wool insulation, thickness of 30 mm and density of 80 kg/m³ penetration seals in flexible wall, made with use of PiroCoat A in accordance with Annex A and Annex C1.

Pipe material	Pipe diameter [mm]	Pipe wall thickness [mm]	PiroCoat A: length x thickness (pipe cover) [mm]	PiroCoat A length x thickness (supporting construction cover) [mm]	Fire resistance class
Cooper	DN ≤ 18	≥ 1,2	50 x 0,6	50 x 0,6	EI 120 - C/C EI 120 - C/U
	18 < DN ≤ 25	≥ 1,3	50 x 0,6	50 x 0,6	
	25 < DN ≤ 30	1,4 – 14,2	50 x 0,6	50 x 0,6	
	30 < DN ≤ 35	1,5 – 14,2	50 x 0,6	50 x 0,6	
Steel	DN ≤ 18	≥ 1,2	50 x 0,6	50 x 0,6	
	18 < DN ≤ 25	≥ 1,3	50 x 0,6	50 x 0,6	
	25 < DN ≤ 30	1,4 – 14,2	50 x 0,6	50 x 0,6	
	30 < DN ≤ 35	1,5 – 14,2	50 x 0,6	50 x 0,6	
Cast iron	DN ≤ 18	≥ 1,2	50 x 0,6	50 x 0,6	
	18 < DN ≤ 25	≥ 1,3	50 x 0,6	50 x 0,6	
	25 < DN ≤ 30	1,4 – 14,2	50 x 0,6	50 x 0,6	
	30 < DN ≤ 35	1,5 – 14,2	50 x 0,6	50 x 0,6	
wall thickness ≥ 100 mm					

PiroCoating, PiroCoat I and PiroCoat A

Penetration seals made with use of PiroCoat A
Insulated metal pipes penetration seals in flexible wall

Annex B1
of European
Technical Assessment
ETA-17/1062

Table B2. Resistance to fire classification of metal pipes with continuous mineral wool insulation, thickness of 30 mm and density of 80 kg/m³ penetration seals in rigid wall, made with use of PiroCoat A in accordance with Annex A and Annex C2.

Pipe material	Pipe diameter [mm]	Pipe wall thickness [mm]	PiroCoat A: length x thickness (pipe cover) [mm]	PiroCoat A: length x thickness (supporting construction cover) [mm]	Fire resistance class
Cooper	DN ≤ 10	≥ 0,8	50 x 0,6	50 x 0,6	EI 120 - C/C EI 120 - C/U
	10 < DN ≤ 15	≥ 1,1	50 x 0,6	50 x 0,6	
	15 < DN ≤ 18	≥ 1,2	50 x 0,6	50 x 0,6	
	18 < DN ≤ 25	≥ 1,3	50 x 0,6	50 x 0,6	
	25 < DN ≤ 30	1,4 – 14,2	50 x 0,6	50 x 0,6	
	30 < DN ≤ 35	1,5 – 14,2	50 x 0,6	50 x 0,6	
Steel	DN ≤ 10	≥ 0,8	50 x 0,6	50 x 0,6	
	10 < DN ≤ 15	≥ 1,1	50 x 0,6	50 x 0,6	
	15 < DN ≤ 18	≥ 1,2	50 x 0,6	50 x 0,6	
	18 < DN ≤ 25	≥ 1,3	50 x 0,6	50 x 0,6	
	25 < DN ≤ 30	1,4 – 14,2	50 x 0,6	50 x 0,6	
	30 < DN ≤ 35	1,5 – 14,2	50 x 0,6	50 x 0,6	
	35 < DN ≤ 40	1,6 – 14,2	50 x 0,6	50 x 0,6	
	40 < DN ≤ 50	1,9 – 14,2	50 x 0,6	50 x 0,6	
	50 < DN ≤ 60	2,2 – 14,2	50 x 0,6	50 x 0,6	
	60 < DN ≤ 70	2,4 – 14,2	50 x 0,6	50 x 0,6	
	70 < DN ≤ 80	2,7 – 14,2	50 x 0,6	50 x 0,6	
	80 < DN ≤ 90	3,0 – 14,2	50 x 0,6	50 x 0,6	
90 < DN ≤ 100	3,2 – 14,2	50 x 0,6	50 x 0,6		
100 < DN ≤ 110	3,5 – 14,2	50 x 0,6	50 x 0,6		
110 < DN ≤ 114,3	3,6 – 14,2	50 x 0,6	50 x 0,6		
wall thickness ≥ 100 mm					

PiroCoating, PiroCoat I and PiroCoat A

Penetration seals made with use of PiroCoat A
Insulated metal pipes penetration seals in rigid wall

Annex B2
of European
Technical Assessment
ETA-17/1062

Table B2. Resistance to fire classification of metal pipes with continuous mineral wool insulation, thickness of 30 mm and density of 80 kg/m³ penetration seals in rigid wall, made with use of PiroCoat A in accordance with Annex A and Annex C2 (continued).

Pipe material	Pipe diameter [mm]	Pipe wall thickness [mm]	PiroCoat A: length x thickness (pipe cover) [mm]	PiroCoat A: length x thickness (supporting construction cover) [mm]	Fire resistance class
Cast iron	DN ≤ 10	≥ 0,8	50 x 0,6	50 x 0,6	EI 120 - C/C EI 120 - C/U
	10 < DN ≤ 15	≥ 1,1	50 x 0,6	50 x 0,6	
	15 < DN ≤ 18	≥ 1,2	50 x 0,6	50 x 0,6	
	18 < DN ≤ 25	≥ 1,3	50 x 0,6	50 x 0,6	
	25 < DN ≤ 30	1,4 – 14,2	50 x 0,6	50 x 0,6	
	30 < DN ≤ 35	1,5 – 14,2	50 x 0,6	50 x 0,6	
	35 < DN ≤ 40	1,6 – 14,2	50 x 0,6	50 x 0,6	
	40 < DN ≤ 50	1,9 – 14,2	50 x 0,6	50 x 0,6	
	50 < DN ≤ 60	2,2 – 14,2	50 x 0,6	50 x 0,6	
	60 < DN ≤ 70	2,4 – 14,2	50 x 0,6	50 x 0,6	
	70 < DN ≤ 80	2,7 – 14,2	50 x 0,6	50 x 0,6	
	80 < DN ≤ 90	3,0 – 14,2	50 x 0,6	50 x 0,6	
	90 < DN ≤ 100	3,2 – 14,2	50 x 0,6	50 x 0,6	
	100 < DN ≤ 110	3,5 – 14,2	50 x 0,6	50 x 0,6	
	110 < DN ≤ 114,3	3,6 – 14,2	50 x 0,6	50 x 0,6	
wall thickness ≥ 100 mm					

PiroCoating, PiroCoat I and PiroCoat A

Penetration seals made with use of PiroCoat A
Insulated metal pipes penetration seals in rigid wall

Annex B2
of European
Technical Assessment
ETA-17/1062

Table B3. Resistance to fire classification metal pipes bundles (max. 4 pipes in bundle) with continuous mineral wool insulation, thickness of 30 mm and density of 50 kg/m³ penetration seals in flexible or rigid wall, made with use of PiroCoat A in accordance with Annex A and Annex C3.

Pipe material	Pipe diameter [mm]	Pipe wall thickness [mm]	PiroCoat A: length x thickness (pipe cover) [mm]	PiroCoat A: length x thickness (supporting construction cover) [mm]	Fire resistance class
Cooper	DN ≤ 10	≥ 0,8	50 x 0,6	50 x 0,6	EI 120 - C/C EI 120 - C/U
Steel	DN ≤ 10	≥ 0,8	50 x 0,6	50 x 0,6	
Cast iron	DN ≤ 10	≥ 0,8	50 x 0,6	50 x 0,6	
wall thickness ≥ 100 mm					

PiroCoating, PiroCoat I and PiroCoat A

Penetration seals made with use of PiroCoat A
Insulated metal pipes bundle penetration seals in flexible or rigid wall

Annex B3
of European
Technical Assessment
ETA-17/1062

Table B4. Resistance to fire classification of metal pipes with local mineral wool insulation, length of 500 mm, width of 50 mm and density of 60 kg/m³ penetration seals in flexible or rigid wall, made with use of PiroCoat A in accordance with Annex A and Annex C4.

Pipe material	Pipe diameter [mm]	Pipe wall thickness [mm]	PiroCoat A: length x thickness (pipe cover) [mm]	PiroCoat A: length x thickness (supporting construction cover) [mm]	Fire resistance class
Cooper	DN ≤ 10	≥ 0,8	50 x 0,6	50 x 0,6	EI 120 - C/C EI 120 - C/U
	10 < DN ≤ 20	≥ 1,0	50 x 0,6	50 x 0,6	EI 60 / E 120 - C/C EI 60 / E 120 - C/U
	20 < DN ≤ 30	1,2 – 14,2	50 x 0,6	50 x 0,6	
	30 < DN ≤ 40	1,4 – 14,2	50 x 0,6	50 x 0,6	
	40 < DN ≤ 50	1,6 – 14,2	50 x 0,6	50 x 0,6	
	50 < DN ≤ 60	1,9 – 14,2	50 x 0,6	50 x 0,6	
	60 < DN ≤ 70	2,1 – 14,2	50 x 0,6	50 x 0,6	
	70 < DN ≤ 80	2,3 – 14,2	50 x 0,6	50 x 0,6	
	80 < DN ≤ 90	2,5 – 14,2	50 x 0,6	50 x 0,6	
	90 < DN ≤ 100	2,7 – 14,2	50 x 0,6	50 x 0,6	
	100 < DN ≤ 108	2,87 – 14,2	50 x 0,6	50 x 0,6	
Steel	DN ≤ 10	≥ 0,8	50 x 0,6	50 x 0,6	EI 120 - C/C EI 120 - C/U
	10 < DN ≤ 20	≥ 1,0	50 x 0,6	50 x 0,6	
	20 < DN ≤ 30	1,2 – 14,2	50 x 0,6	50 x 0,6	
	30 < DN ≤ 40	1,4 – 14,2	50 x 0,6	50 x 0,6	
	40 < DN ≤ 50	1,6 – 14,2	50 x 0,6	50 x 0,6	
	50 < DN ≤ 60	1,8 – 14,2	50 x 0,6	50 x 0,6	
	60 < DN ≤ 70	2,1 – 14,2	50 x 0,6	50 x 0,6	
	70 < DN ≤ 80	2,3 – 14,2	50 x 0,6	50 x 0,6	
	80 < DN ≤ 90	2,5 – 14,2	50 x 0,6	50 x 0,6	
	90 < DN ≤ 100	2,7 – 14,2	50 x 0,6	50 x 0,6	
	100 < DN ≤ 110	2,9 – 14,2	50 x 0,6	50 x 0,6	
	110 < DN ≤ 120	3,1 – 14,2	50 x 0,6	50 x 0,6	
	120 < DN ≤ 130	3,3 – 14,2	50 x 0,6	50 x 0,6	
	130 < DN ≤ 140	3,5 – 14,2	50 x 0,6	50 x 0,6	
	140 < DN ≤ 150	3,7 – 14,2	50 x 0,6	50 x 0,6	
	150 < DN ≤ 160	3,9 – 14,2	50 x 0,6	50 x 0,6	
	160 < DN ≤ 170	4,1 – 14,2	50 x 0,6	50 x 0,6	
170 < DN ≤ 180	4,4 – 14,2	50 x 0,6	50 x 0,6		
180 < DN ≤ 190	4,6 – 14,2	50 x 0,6	50 x 0,6		
wall thickness ≥ 125 mm					

PiroCoating, PiroCoat I and PiroCoat A

Penetration seals made with use of PiroCoat A
Insulated metal pipes penetration seals in flexible or rigid wall

Annex B4
of European
Technical Assessment
ETA-17/1062

Table B4. Resistance to fire classification of metal pipes with local mineral wool insulation, length of 500 mm, width of 50 mm and density of 60 kg/m³ penetration seals in flexible or rigid wall, made with use of PiroCoat A in accordance with Annex A and Annex C4, (continued).

Pipe material	Pipe diameter [mm]	Pipe wall thickness [mm]	PiroCoat A: length x thickness (pipe cover) [mm]	PiroCoat A: length x thickness (supporting construction cover) [mm]	Fire resistance class
Steel	190 < DN ≤ 200	4,8 – 14,2	50 x 0,6	50 x 0,6	EI 120 - C/C EI 120 - C/U
	200 < DN ≤ 210	5,0 – 14,2	50 x 0,6	50 x 0,6	
	210 < DN ≤ 220	5,2 – 14,2	50 x 0,6	50 x 0,6	
	220 < DN ≤ 230	5,4 – 14,2	50 x 0,6	50 x 0,6	
	230 < DN ≤ 240	5,6 – 14,2	50 x 0,6	50 x 0,6	
	240 < DN ≤ 250	5,8 – 14,2	50 x 0,6	50 x 0,6	
	250 < DN ≤ 260	6,0 – 14,2	50 x 0,6	50 x 0,6	
	260 < DN ≤ 273	6,3 – 14,2	50 x 0,6	50 x 0,6	
Cast iron	DN ≤ 10	≥ 0,8	50 x 0,6	50 x 0,6	
	10 < DN ≤ 20	≥ 1,0	50 x 0,6	50 x 0,6	
	20 < DN ≤ 30	1,2 – 14,2	50 x 0,6	50 x 0,6	
	30 < DN ≤ 40	1,4 – 14,2	50 x 0,6	50 x 0,6	
	40 < DN ≤ 50	1,6 – 14,2	50 x 0,6	50 x 0,6	
	50 < DN ≤ 60	1,8 – 14,2	50 x 0,6	50 x 0,6	
	60 < DN ≤ 70	2,1 – 14,2	50 x 0,6	50 x 0,6	
	70 < DN ≤ 80	2,3 – 14,2	50 x 0,6	50 x 0,6	
	80 < DN ≤ 90	2,5 – 14,2	50 x 0,6	50 x 0,6	
	90 < DN ≤ 100	2,7 – 14,2	50 x 0,6	50 x 0,6	
	100 < DN ≤ 110	2,9 – 14,2	50 x 0,6	50 x 0,6	
	110 < DN ≤ 120	3,1 – 14,2	50 x 0,6	50 x 0,6	
	120 < DN ≤ 130	3,3 – 14,2	50 x 0,6	50 x 0,6	
	130 < DN ≤ 140	3,5 – 14,2	50 x 0,6	50 x 0,6	
	140 < DN ≤ 150	3,7 – 14,2	50 x 0,6	50 x 0,6	
	150 < DN ≤ 160	3,9 – 14,2	50 x 0,6	50 x 0,6	
	160 < DN ≤ 170	4,1 – 14,2	50 x 0,6	50 x 0,6	
	170 < DN ≤ 180	4,4 – 14,2	50 x 0,6	50 x 0,6	
	180 < DN ≤ 190	4,6 – 14,2	50 x 0,6	50 x 0,6	
	190 < DN ≤ 200	4,8 – 14,2	50 x 0,6	50 x 0,6	
200 < DN ≤ 210	5,0 – 14,2	50 x 0,6	50 x 0,6		
210 < DN ≤ 220	5,2 – 14,2	50 x 0,6	50 x 0,6		
wall thickness ≥ 125 mm					

PiroCoating, PiroCoat I and PiroCoat A

Penetration seals made with use of PiroCoat A
Insulated metal pipes penetration seals in flexible or rigid wall

Annex B4
of European
Technical Assessment
ETA-17/1062

Table B4. Resistance to fire classification of metal pipes with local mineral wool insulation, length of 500 mm, width of 50 mm and density of 60 kg/m³ penetration seals in flexible or rigid wall, made with use of PiroCoat A in accordance with Annex A and Annex C4, (continued).

Pipe material	Pipe diameter [mm]	Pipe wall thickness [mm]	PiroCoat A: length x thickness (pipe cover) [mm]	PiroCoat A: length x thickness (supporting construction cover) [mm]	Fire resistance class
Cast iron	220 < DN ≤ 230	5,4 – 14,2	50 x 0,6	50 x 0,6	EI 120 - C/C EI 120 - C/U
	230 < DN ≤ 240	5,6 – 14,2	50 x 0,6	50 x 0,6	
	240 < DN ≤ 250	5,8 – 14,2	50 x 0,6	50 x 0,6	
	250 < DN ≤ 260	6,0 – 14,2	50 x 0,6	50 x 0,6	
	260 < DN ≤ 273	6,3 – 14,2	50 x 0,6	50 x 0,6	
Steel spiro	DN ≤ 80	0,8 – 14,2	50 x 0,6	50 x 0,6	EI 30 / E 120 - C/C EI 30 / E 120 - C/U
	80 < DN ≤ 160	0,8 – 14,2	50 x 0,6	50 x 0,6	
wall thickness ≥ 125 mm					

PiroCoating, PiroCoat I and PiroCoat A

Penetration seals made with use of PiroCoat A
Insulated metal pipes penetration seals in flexible or rigid wall

Annex B4
of European
Technical Assessment
ETA-17/1062

Table B5. Resistance to fire classification of metal pipes with local mineral wool insulation, length of 500 mm, width of 50 mm and density of 70 kg/m³ or 80 kg/m³ penetration seals in rigid wall, made with use of PiroCoat A in accordance with Annex A and Annex C5.

Pipe material	Pipe diameter [mm]	Pipe wall thickness [mm]	PiroCoat A: length x thickness (pipe cover) [mm]	PiroCoat A: length x thickness (supporting construction cover) [mm]	Fire resistance class
Cooper ¹⁾	DN ≤ 10	≥ 0,8	60 x 0,6	50 x 0,6	EI 120 - C/C EI 120 - C/U
	10 < DN ≤ 20	≥ 1,0	60 x 0,6	50 x 0,6	
	20 < DN ≤ 30	1,2 – 14,2	60 x 0,6	50 x 0,6	
	30 < DN ≤ 42	1,4 – 14,2	60 x 0,6	50 x 0,6	
	42 < DN ≤ 50	1,5 – 14,2	60 x 0,6	50 x 0,6	EI 60 / E 120 - C/C EI 60 / E 120 - C/U
	50 < DN ≤ 60	1,6 – 14,2	60 x 0,6	50 x 0,6	
	60 < DN ≤ 70	1,8 – 14,2	60 x 0,6	50 x 0,6	
	70 < DN ≤ 80	1,9 – 14,2	60 x 0,6	50 x 0,6	
	80 < DN ≤ 90	2,1 – 14,2	60 x 0,6	50 x 0,6	
	90 < DN ≤ 100	2,2 – 14,2	60 x 0,6	50 x 0,6	
	100 < DN ≤ 108	2,3 – 14,2	60 x 0,6	50 x 0,6	
Steel ¹⁾	DN ≤ 10	≥ 0,8	60 x 0,6	50 x 0,6	EI 120 - C/C EI 120 - C/U
	10 < DN ≤ 20	≥ 1,0	60 x 0,6	50 x 0,6	
	20 < DN ≤ 30	1,2 – 14,2	60 x 0,6	50 x 0,6	
	30 < DN ≤ 42	1,4 – 14,2	60 x 0,6	50 x 0,6	
	42 < DN ≤ 50	1,5 – 14,2	60 x 0,6	50 x 0,6	EI 60 E 120 - C/C EI 60 E 120 - C/U
	50 < DN ≤ 60	1,6 – 14,2	60 x 0,6	50 x 0,6	
	60 < DN ≤ 70	1,8 – 14,2	60 x 0,6	50 x 0,6	
	70 < DN ≤ 80	1,9 – 14,2	60 x 0,6	50 x 0,6	
	80 < DN ≤ 90	2,1 – 14,2	60 x 0,6	50 x 0,6	
	90 < DN ≤ 100	2,2 – 14,2	60 x 0,6	50 x 0,6	
	100 < DN ≤ 108	2,3 – 14,2	60 x 0,6	50 x 0,6	
wall thickness ≥ 150 mm					
¹⁾ mineral wool insulation density of 70 kg/m ³					
²⁾ mineral wool insulation density of 80 kg/m ³					

PiroCoating, PiroCoat I and PiroCoat A

Penetration seals made with use of PiroCoat A
Insulated metal pipes penetration seals in rigid wall

Annex B5
of European
Technical Assessment
ETA-17/1062

Table B5. Resistance to fire classification of metal pipes with local mineral wool insulation, length of 500 mm, width of 50 mm and density of 70 kg/m³ or 80 kg/m³ penetration seals in rigid wall, made with use of PiroCoat A in accordance with Annex A and Annex C5 (continued).

Pipe material	Pipe diameter [mm]	Pipe wall thickness [mm]	PiroCoat A: length x thickness (pipe cover) [mm]	PiroCoat A: length x thickness (supporting construction cover) [mm]	Fire resistance class
Cast iron ¹⁾	DN ≤ 10	≥ 0,8	60 x 0,6	50 x 0,6	EI 120 - C/C EI 120 - C/U
	10 < DN ≤ 20	≥ 1,0	60 x 0,6	50 x 0,6	
	20 < DN ≤ 30	1,2 – 14,2	60 x 0,6	50 x 0,6	
	30 < DN ≤ 42	1,4 – 14,2	60 x 0,6	50 x 0,6	
	42 < DN ≤ 50	1,5 – 14,2	60 x 0,6	50 x 0,6	EI 60 / E 120 - C/C EI 60 / E 120 - C/U
	50 < DN ≤ 60	1,6 – 14,2	60 x 0,6	50 x 0,6	
	60 < DN ≤ 70	1,8 – 14,2	60 x 0,6	50 x 0,6	
	70 < DN ≤ 80	1,9 – 14,2	60 x 0,6	50 x 0,6	
	80 < DN ≤ 90	2,1 – 14,2	60 x 0,6	50 x 0,6	
	90 < DN ≤ 100	2,2 – 14,2	60 x 0,6	50 x 0,6	
	100 < DN ≤ 108	2,3 – 14,2	60 x 0,6	50 x 0,6	
Steel spiro ²⁾	DN ≤ 80	0,8 – 14,2	60 x 0,6	50 x 0,6	EI 120 - C/C EI 120 - C/U
	80 < DN ≤ 160	0,8 – 14,2	60 x 0,6	50 x 0,6	EI 60 / E 120 - C/C EI 60 / E 120 - C/U
wall thickness ≥ 150 mm					
¹⁾ mineral wool insulation density of 70 kg/m ³					
²⁾ mineral wool insulation density of 80 kg/m ³					

PiroCoating, PiroCoat I and PiroCoat A

Penetration seals made with use of PiroCoat A
Insulated metal pipes penetration seals in rigid wall

Annex B5
of European
Technical Assessment
ETA-17/1062

Table B6. Resistance to fire classification of metal pipes without insulation penetration seals in flexible wall, made with use of PiroCoat I in accordance with Annex A and Annex C6.

Pipe material	Pipe diameter [mm]	Pipe wall thickness [mm]	PiroCoat I: length x thickness (pipe cover) [mm]	Fire resistance class
Cooper	DN ≤ 10	≥ 0,8	500 x 1,2	EI 120 - C/C EI 120 - C/U
Steel	DN ≤ 10	≥ 0,8	500 x 1,2	
	10 < DN ≤ 15	≥ 1,1	500 x 1,2	
	15 < DN ≤ 18	≥ 1,2	500 x 1,2	
	18 < DN ≤ 25	≥ 1,3	500 x 1,2	
	25 < DN ≤ 30	1,4 – 14,2	500 x 1,2	
	30 < DN ≤ 35	1,5 – 14,2	500 x 1,2	
	35 < DN ≤ 40	1,6 – 14,2	500 x 1,2	
	40 < DN ≤ 50	1,8 – 14,2	500 x 1,2	
50 < DN ≤ 63,9	2,0 – 14,2	500 x 1,2		
Cast iron	DN ≤ 10	≥ 0,8	500 x 1,2	
	10 < DN ≤ 15	≥ 1,1	500 x 1,2	
	15 < DN ≤ 18	≥ 1,2	500 x 1,2	
	18 < DN ≤ 25	≥ 1,3	500 x 1,2	
	25 < DN ≤ 30	1,4 – 14,2	500 x 1,2	
	30 < DN ≤ 35	1,5 – 14,2	500 x 1,2	
	35 < DN ≤ 40	1,6 – 14,2	500 x 1,2	
	40 < DN ≤ 50	1,8 – 14,2	500 x 1,2	
50 < DN ≤ 63,9	2,0 – 14,2	500 x 1,2		
wall thickness ≥ 100 mm				

PiroCoating, PiroCoat I and PiroCoat A

Penetration seals made with use of PiroCoat I
Non-insulated metal pipes penetration seals in flexible wall

Annex B6
of European
Technical Assessment
ETA-17/1062

Table B7. Resistance to fire classification of metal pipes without insulation penetration seals in rigid wall, made with use of PiroCoat I in accordance with Annex A and Annex C7.

Pipe material	Pipe diameter [mm]	Pipe wall thickness [mm]	PiroCoat I: length x thickness (pipe cover) [mm]	Fire resistance class
Cooper	DN ≤ 10	≥ 0,8	500 x 1,2	EI 120 - C/C EI 120 - C/U
	10 < DN ≤ 15	≥ 1,1	500 x 1,2	
	15 < DN ≤ 18	≥ 1,2	500 x 1,2	
	18 < DN ≤ 25	≥ 1,3	500 x 1,2	
	25 < DN ≤ 30	1,4 – 14,2	500 x 1,2	
	30 < DN ≤ 35	1,5 – 14,2	500 x 1,2	
Steel	DN ≤ 10	≥ 0,8	500 x 1,2	
	10 < DN ≤ 15	≥ 1,1	500 x 1,2	
	15 < DN ≤ 18	≥ 1,2	500 x 1,2	
	18 < DN ≤ 25	≥ 1,3	500 x 1,2	
	25 < DN ≤ 30	1,4 – 14,2	500 x 1,2	
	30 < DN ≤ 35	1,5 – 14,2	500 x 1,2	
	35 < DN ≤ 40	1,6 – 14,2	500 x 1,2	
	40 < DN ≤ 50	1,8 – 14,2	500 x 1,2	
50 < DN ≤ 63,9	2,0 – 14,2	500 x 1,2		
Cast iron	DN ≤ 10	≥ 0,8	500 x 1,2	
	10 < DN ≤ 15	≥ 1,1	500 x 1,2	
	15 < DN ≤ 18	≥ 1,2	500 x 1,2	
	18 < DN ≤ 25	≥ 1,3	500 x 1,2	
	25 < DN ≤ 30	1,4 – 14,2	500 x 1,2	
	30 < DN ≤ 35	1,5 – 14,2	500 x 1,2	
	35 < DN ≤ 40	1,6 – 14,2	500 x 1,2	
	40 < DN ≤ 50	1,8 – 14,2	500 x 1,2	
	50 < DN ≤ 63,9	2,0 – 14,2	500 x 1,2	
wall thickness ≥ 100 mm				

PiroCoating, PiroCoat I and PiroCoat A

Penetration seals made with use of PiroCoat I
Non-insulated metal pipes penetration seals in rigid wall

Annex B7
of European
Technical Assessment
ETA-17/1062

Table B8. Resistance to fire classification of metal or plastic pipes without insulation penetration seals in rigid wall, made with use of PiroCoat I in accordance with Annex A and Annex C8.

Pipe material	Pipe diameter [mm]	Pipe wall thickness [mm]	PiroCoat I: length x thickness (pipe cover) [mm]	PiroCoat I: length x thickness (supporting construction cover) [mm]	Fire resistance class
Steel	DN ≤ 42,4	4,3 – 14,2	500 x 1,2	50 x 0,6	EI 120 - C/C EI 120 - C/U
	42,4 < DN ≤ 50	4,4 – 14,2	500 x 1,2	50 x 0,6	
	50 < DN ≤ 60	4,6 – 14,2	500 x 1,2	50 x 0,6	
	60 < DN ≤ 70	4,8 – 14,2	500 x 1,2	50 x 0,6	
	70 < DN ≤ 80	5,0 – 14,2	500 x 1,2	50 x 0,6	
	80 < DN ≤ 90	5,2 – 14,2	500 x 1,2	50 x 0,6	
	90 < DN ≤ 100	5,3 – 14,2	500 x 1,2	50 x 0,6	
	100 < DN ≤ 110	5,5 – 14,2	500 x 1,2	50 x 0,6	
	110 < DN ≤ 120	5,7 – 14,2	500 x 1,2	50 x 0,6	
	120 < DN ≤ 130	5,9 – 14,2	500 x 1,2	50 x 0,6	
	130 < DN ≤ 140	6,1 – 14,2	500 x 1,2	50 x 0,6	
	140 < DN ≤ 150	6,3 – 14,2	500 x 1,2	50 x 0,6	
	150 < DN ≤ 159	6,4 – 14,2	500 x 1,2	50 x 0,6	
	159 < DN ≤ 170	6,6 – 14,2	500 x 1,2	50 x 0,6	
	170 < DN ≤ 180	6,8 – 14,2	500 x 1,2	50 x 0,6	
	180 < DN ≤ 190	7,0 – 14,2	500 x 1,2	50 x 0,6	
	190 < DN ≤ 200	7,2 – 14,2	500 x 1,2	50 x 0,6	
	200 < DN ≤ 210	7,4 – 14,2	500 x 1,2	50 x 0,6	
	210 < DN ≤ 220	7,5 – 14,2	500 x 1,2	50 x 0,6	
	220 < DN ≤ 230	7,7 – 14,2	500 x 1,2	50 x 0,6	
230 < DN ≤ 240	7,9 – 14,2	500 x 1,2	50 x 0,6		
240 < DN ≤ 250	7,9 – 14,2	500 x 1,2	50 x 0,6		
250 < DN ≤ 260	8,3 – 14,2	500 x 1,2	50 x 0,6		
260 < DN ≤ 273	8,5 – 14,2	500 x 1,2	50 x 0,6		
wall thickness ≥ 150 mm					

PiroCoating, PiroCoat I and PiroCoat A

Penetration seals made with use of PiroCoat I
Non-insulated metal or plastic pipes penetration seals in rigid wall

Annex B8
of European
Technical Assessment
ETA-17/1062

Table B8. Resistance to fire classification of metal or plastic pipes without insulation penetration seals in rigid wall, made with use of PiroCoat I in accordance with Annex A and Annex C8 (continued).

Pipe material	Pipe diameter [mm]	Pipe wall thickness [mm]	PiroCoat I: length x thickness (pipe cover) [mm]	PiroCoat I: length x thickness (supporting construction cover) [mm]	Fire resistance class
Cast iron	DN ≤ 50	3,4 – 14,2	500 x 1,2	50 x 0,6	EI 120 - C/C EI 120 - C/U
	50 < DN ≤ 60	3,5 – 14,2	500 x 1,2	50 x 0,6	
	60 < DN ≤ 70	3,7 – 14,2	500 x 1,2	50 x 0,6	
	70 < DN ≤ 80	3,8 – 14,2	500 x 1,2	50 x 0,6	
	80 < DN ≤ 90	4,0 – 14,2	500 x 1,2	50 x 0,6	
	90 < DN ≤ 100	4,1 – 14,2	500 x 1,2	50 x 0,6	
	100 < DN ≤ 110	4,3 – 14,2	500 x 1,2	50 x 0,6	
	110 < DN ≤ 120	4,4 – 14,2	500 x 1,2	50 x 0,6	
	120 < DN ≤ 130	4,6 – 14,2	500 x 1,2	50 x 0,6	
	130 < DN ≤ 140	4,7 – 14,2	500 x 1,2	50 x 0,6	
	140 < DN ≤ 150	4,8 – 14,2	500 x 1,2	50 x 0,6	
	150 < DN ≤ 159	5,0 – 14,2	500 x 1,2	50 x 0,6	
	159 < DN ≤ 170	5,1 – 14,2	500 x 1,2	50 x 0,6	
	170 < DN ≤ 180	5,3 – 14,2	500 x 1,2	50 x 0,6	
	180 < DN ≤ 190	5,4 – 14,2	500 x 1,2	50 x 0,6	
	190 < DN ≤ 200	5,6 – 14,2	500 x 1,2	50 x 0,6	
	200 < DN ≤ 210	5,7 – 14,2	500 x 1,2	50 x 0,6	
	210 < DN ≤ 220	6,1 – 14,2	500 x 1,2	50 x 0,6	
	220 < DN ≤ 230	6,6 – 14,2	500 x 1,2	50 x 0,6	
	230 < DN ≤ 240	7,0 – 14,2	500 x 1,2	50 x 0,6	
240 < DN ≤ 250	7,5 – 14,2	500 x 1,2	50 x 0,6		
250 < DN ≤ 260	7,9 – 14,2	500 x 1,2	50 x 0,6		
260 < DN ≤ 273	8,5 – 14,2	500 x 1,2	50 x 0,6		
PE-X	DN ≤ 17	1,9	500 x 1,2	50 x 0,6	
wall thickness ≥ 150 mm					

PiroCoating, PiroCoat I and PiroCoat A

Penetration seals made with use of PiroCoat I
Non-insulated metal or plastic pipes penetration seals in rigid wall

Annex B8
of European
Technical Assessment
ETA-17/1062

Table B9. Resistance to fire classification of plastic pipes with mineral wool insulation, density of 50 kg/m³ penetration seals in rigid wall, made with use of PiroCoat I in accordance with Annex A and Annex C9.

Pipe material	Pipe diameter [mm]	Pipe wall thickness [mm]	PiroCoat I: length x thickness (supporting construction cover) [mm]	Fire resistance class
PE-HD	DN ≤ 40	2,4	15,0 x 4,0	EI 120 - C/C EI 120 - C/U
PP	DN ≤ 40	1,8	15,0 x 4,0	
PVC-U	DN ≤ 40	1,9	15,0 x 4,0	
wall thickness ≥ 150 mm				

PiroCoating, PiroCoat I and PiroCoat A

Penetration seals made with use of PiroCoat I
Insulated plastic pipes penetration seals in rigid wall

Annex B9
of European
Technical Assessment
ETA-17/1062

Table B10. Resistance to fire classification of metal pipes with PE foam insulation, thickness of max 32 mm, penetration seals in rigid wall, made with use of PiroCoat I and Piro Multitube PM width of 100 mm and thickness 4,8 mm, in accordance with Annex A and Annex C10.

Pipe material	Pipe diameter [mm]	Pipe wall thickness [mm]	PiroCoat I: length x thickness (pipe cover) [mm]	Fire resistance class
Cooper	DN ≤ 35	1,5 – 14,2	500 x 1,2	EI 120 - C/C EI 120 - C/U
Steel	DN ≤ 35	1,5 – 14,2	500 x 1,2	
Cast iron	DN ≤ 35	1,5 – 14,2	500 x 1,2	
wall thickness ≥ 100 mm				

PiroCoating, PiroCoat I and PiroCoat A

Penetration seals made with use of PiroCoat I
Insulated metal pipes penetration seals in rigid wall

Annex B10
of European
Technical Assessment
ETA-17/1062

Table B11. Resistance to fire classification of small cables ($\varnothing \leq 21$ mm) penetration seals in flexible or rigid wall thickness of $t \geq 125$ mm, made with use of PiroCoating in accordance with Annex A and Annex C11.

Fire resistance class: EI 120

PiroCoating, PiroCoat I and PiroCoat A	Annex B11 of European Technical Assessment ETA-17/1062
Penetration seals made with use of PiroCoating Cables penetration seals in flexible or rigid wall	

Table B12. Resistance to fire classification of single small cables ($\varnothing \leq 13$ mm) penetration seals in flexible or rigid wall thickness of $t \geq 100$ mm, made with use of PiroCoating in accordance with Annex A and Annex C12.

Fire resistance class: EI 120

PiroCoating, PiroCoat I and PiroCoat A	Annex B12 of European Technical Assessment ETA-17/1062
Penetration seals made with use of PiroCoating Cables penetration seals in flexible or rigid wall	

Table B13. Resistance to fire classification of metal pipes with continuous flexible elastomeric foam (FEF) insulation thickness of 32 mm penetration sealed with use of Piro Multitube PM width of 100 mm and thickness of 4,8 mm with additional single small cable ($\varnothing \leq 13$ mm) penetration sealed with use of PiroCoating in rigid wall, in accordance with Annex A and Annex C13.

Pipe material	Pipe diameter [mm]	Pipe wall thickness [mm]	PiroCoating length x thickness (pipe cover) [mm]	PiroCoating length x thickness (supporting construction cover) [mm]	Fire resistance class
Cooper	DN \leq 10	$\geq 0,8$	300 x 1,2	50 x 0,6	EI 120 - C/C EI 120 - C/U
	10 < DN \leq 20	1,1 – 14,2	300 x 1,2	50 x 0,6	EI 60 / E 120 - C/C
	20 < DN \leq 30	1,4 – 14,2	300 x 1,2	50 x 0,6	EI 60 / E 120 - C/U
	30 < DN \leq 35	1,5 – 14,2	300 x 1,2	50 x 0,6	EI 60 / E 120 - C/U
Steel	DN \leq 10	$\geq 0,8$	300 x 1,2	50 x 0,6	EI 120 - C/C EI 120 - C/U
	10 < DN \leq 20	1,1 – 14,2	300 x 1,2	50 x 0,6	EI 60 / E 120 - C/C
	20 < DN \leq 30	1,4 – 14,2	300 x 1,2	50 x 0,6	EI 60 / E 120 - C/U
	30 < DN \leq 35	1,5 – 14,2	300 x 1,2	50 x 0,6	EI 60 / E 120 - C/U
Cast iron	DN \leq 10	$\geq 0,8$	300 x 1,2	50 x 0,6	EI 120 - C/C EI 120 - C/U
	10 < DN \leq 20	1,1 – 14,2	300 x 1,2	50 x 0,6	EI 60 / E 120 - C/C
	20 < DN \leq 30	1,4 – 14,2	300 x 1,2	50 x 0,6	EI 60 / E 120 - C/U
	30 < DN \leq 35	1,5 – 14,2	300 x 1,2	50 x 0,6	EI 60 / E 120 - C/U
wall thickness \geq 100 mm					

PiroCoating, PiroCoat I and PiroCoat A

Penetration seals made with use of PiroCoating
Insulated metal pipes penetration seals in rigid wall

Annex B13
of European
Technical Assessment
ETA-17/1062

Table B14. Resistance to fire classification of metal pipes with with local mineral wool insulation, length of 500 mm, width of 50 mm and density of 50 kg/m³ penetration seals with use of PiroCoat A in rigid floor, in accordance with Annex A and Annex C14.

Pipe material	Pipe diameter [mm]	Pipe wall thickness [mm]	PiroCoat A length x thickness (pipe cover) [mm]	PiroCoat A length x thickness (supporting construction cover) [mm]	Fire resistance class
Cooper	DN ≤ 10,0	≥ 1,0	50 x 0,6	50 x 0,6	EI 120 - C/C EI 120 - C/U
	10 < DN ≤ 20	≥ 1,2	50 x 0,6	50 x 0,6	EI 60 / E 120 - C/C EI 60 / E 120 - C/U
	20 < DN ≤ 30	1,3 – 14,2	50 x 0,6	50 x 0,6	
	30 < DN ≤ 42	1,5 – 14,2	50 x 0,6	50 x 0,6	
	42 < DN ≤ 50	1,6 – 14,2	50 x 0,6	50 x 0,6	
	50 < DN ≤ 60	1,8 – 14,2	50 x 0,6	50 x 0,6	
	60 < DN ≤ 70	1,9 – 14,2	50 x 0,6	50 x 0,6	
	70 < DN ≤ 80	2,1 – 14,2	50 x 0,6	50 x 0,6	
	80 < DN ≤ 90	2,2 – 14,2	50 x 0,6	50 x 0,6	
	90 < DN ≤ 100	2,4 – 14,2	50 x 0,6	50 x 0,6	
	100 < DN ≤ 108	2,5 – 14,2	50 x 0,6	50 x 0,6	
Steel	DN ≤ 10	≥ 1,0	50 x 0,6	50 x 0,6	EI 120 - C/C EI 120 - C/U
	10 < DN ≤ 17,2	≥ 2,5	50 x 0,6	50 x 0,6	EI 60 / E 120 - C/C EI 60 / E 120 - C/U
	17,2 < DN ≤ 30	1,3 – 14,2	50 x 0,6	50 x 0,6	
	30 < DN ≤ 42	1,5 – 14,2	50 x 0,6	50 x 0,6	
	42 < DN ≤ 50	1,6 – 14,2	50 x 0,6	50 x 0,6	
	50 < DN ≤ 60	1,8 – 14,2	50 x 0,6	50 x 0,6	
	60 < DN ≤ 70	1,9 – 14,2	50 x 0,6	50 x 0,6	
	70 < DN ≤ 80	2,1 – 14,2	50 x 0,6	50 x 0,6	
	80 < DN ≤ 90	2,2 – 14,2	50 x 0,6	50 x 0,6	
	90 < DN ≤ 100	2,4 – 14,2	50 x 0,6	50 x 0,6	
	100 < DN ≤ 108	2,5 – 14,2	50 x 0,6	50 x 0,6	

PiroCoating, PiroCoat I and PiroCoat A

Penetration seals made with use of PiroCoat A
Insulated metal pipes penetration seals in rigid floor

Annex B14
of European
Technical Assessment
ETA-17/1062

Table B14. Resistance to fire classification of metal pipes with with local mineral wool insulation, length of 500 mm, width of 50 mm and density of 50 kg/m³ penetration seals with use of PiroCoat A in rigid floor, in accordance with Annex A and Annex C14 (continued).

Pipe material	Pipe diameter [mm]	Pipe wall thickness [mm]	PiroCoat A length x thickness (pipe cover) [mm]	PiroCoat A length x thickness (supporting construction cover) [mm]	Fire resistance class
Cast iron	DN ≤ 10	≥ 1,0	50 x 0,6	50 x 0,6	EI 120 - C/C EI 120 - C/U
	10 < DN ≤ 17,2	≥ 2,5	50 x 0,6	50 x 0,6	
	17,2 < DN ≤ 30	2,9 – 14,2	50 x 0,6	50 x 0,6	
	30 < DN ≤ 42	3,4 – 14,2	50 x 0,6	50 x 0,6	
	42 < DN ≤ 50	3,6 – 14,2	50 x 0,6	50 x 0,6	
	50 < DN ≤ 60	4,0 – 14,2	50 x 0,6	50 x 0,6	
	60 < DN ≤ 70	1,9 – 14,2	50 x 0,6	50 x 0,6	EI 60 / E 120 - C/C EI 60 / E 120 - C/U
	70 < DN ≤ 80	2,1 – 14,2	50 x 0,6	50 x 0,6	
	80 < DN ≤ 90	2,2 – 14,2	50 x 0,6	50 x 0,6	
	90 < DN ≤ 100	2,4 – 14,2	50 x 0,6	50 x 0,6	
	100 < DN ≤ 108	2,5 – 14,2	50 x 0,6	50 x 0,6	
	108 < DN ≤ 120	2,8 – 14,2	50 x 0,6	50 x 0,6	
	120 < DN ≤ 130	3,1 – 14,2	50 x 0,6	50 x 0,6	
	130 < DN ≤ 140	3,4 – 14,2	50 x 0,6	50 x 0,6	
	140 < DN ≤ 150	3,6 – 14,2	50 x 0,6	50 x 0,6	
	150 < DN ≤ 160	3,9 – 14,2	50 x 0,6	50 x 0,6	
	160 < DN ≤ 170	4,2 – 14,2	50 x 0,6	50 x 0,6	
	170 < DN ≤ 180	4,5 – 14,2	50 x 0,6	50 x 0,6	
	180 < DN ≤ 190	4,7 – 14,2	50 x 0,6	50 x 0,6	
	190 < DN ≤ 200	5,0 – 14,2	50 x 0,6	50 x 0,6	
	200 < DN ≤ 210	5,3 – 14,2	50 x 0,6	50 x 0,6	
	210 < DN ≤ 220	5,5 – 14,2	50 x 0,6	50 x 0,6	
	220 < DN ≤ 230	5,8 – 14,2	50 x 0,6	50 x 0,6	
	230 < DN ≤ 240	6,1 – 14,2	50 x 0,6	50 x 0,6	
240 < DN ≤ 250	6,3 – 14,2	50 x 0,6	50 x 0,6		
250 < DN ≤ 260	6,6 – 14,2	50 x 0,6	50 x 0,6		
260 < DN ≤ 273	7,0 – 14,2	50 x 0,6	50 x 0,6		
274	7,0 – 14,2	50 x 0,6	50 x 0,6		
Steel spiro	DN ≤ 160	0,8 – 14,2	50 x 0,6	50 x 0,6	EI 120 - C/C EI 120 - C/U

PiroCoating, PiroCoat I and PiroCoat A

Penetration seals made with use of PiroCoat A
Insulated metal pipes penetration seals in rigid floor

Annex B14
of European
Technical Assessment
ETA-17/1062

Table B15. Resistance to fire classification of metal pipes with with local mineral wool insulation, length of 500 mm, width of 50 mm and density of 70 kg/m³ penetration seals with use of PiroCoat A in rigid floor, in accordance with Annex A and Annex C14.

Pipe material	Pipe diameter [mm]	Pipe wall thickness [mm]	PiroCoat A length x thickness (pipe cover) [mm]	PiroCoat A length x thickness (supporting construction cover) [mm]	Fire resistance class
Cooper	DN ≤ 10,0	≥ 1,0	50 x 0,6	50 x 0,6	EI 120 - C/C EI 120 - C/U
	10 < DN ≤ 20	≥ 1,2	50 x 0,6	50 x 0,6	EI 90 / E 120 - C/C EI 90 / E 120 - C/U
	20 < DN ≤ 30	1,3 – 14,2	50 x 0,6	50 x 0,6	
	30 < DN ≤ 42	1,5 – 14,2	50 x 0,6	50 x 0,6	
	42 < DN ≤ 50	1,7 – 14,2	50 x 0,6	50 x 0,6	
	50 < DN ≤ 60	1,9 – 14,2	50 x 0,6	50 x 0,6	
	60 < DN ≤ 70	2,1 – 14,2	50 x 0,6	50 x 0,6	
	70 < DN ≤ 80	2,4 – 14,2	50 x 0,6	50 x 0,6	
	80 < DN ≤ 90	2,6 – 14,2	50 x 0,6	50 x 0,6	
	90 < DN ≤ 100	2,8 – 14,2	50 x 0,6	50 x 0,6	
	100 < DN ≤ 108	3,0 – 14,2	50 x 0,6	50 x 0,6	

PiroCoating, PiroCoat I and PiroCoat A

Penetration seals made with use of PiroCoat A
Insulated metal pipes penetration seals in rigid floor

Annex B15
of European
Technical Assessment
ETA-17/1062

Table B16. Resistance to fire classification of metal pipes with with local mineral wool insulation, length of 500 mm, width of 50 mm and density of 60 kg/m³ penetration seals with use of PiroCoat A in rigid floor, in accordance with Annex A and Annex C14.

Pipe material	Pipe diameter [mm]	Pipe wall thickness [mm]	PiroCoat A length x thickness (pipe cover) [mm]	PiroCoat A length x thickness (supporting construction cover) [mm]	Fire resistance class
Steel	DN ≤ 10	≥ 1,0	50 x 0,6	50 x 0,6	EI 120 - C/C EI 120 - C/U
	10 < DN ≤ 17,2	1,1 – 2,4	50 x 0,6	50 x 0,6	
	17,2 < DN ≤ 30	1,4 – 14,2	50 x 0,6	50 x 0,6	
	30 < DN ≤ 42	1,6 – 14,2	50 x 0,6	50 x 0,6	
	42 < DN ≤ 50	1,8 – 14,2	50 x 0,6	50 x 0,6	
	50 < DN ≤ 60	2,0 – 14,2	50 x 0,6	50 x 0,6	
	60 < DN ≤ 70	2,2 – 14,2	50 x 0,6	50 x 0,6	
	70 < DN ≤ 80	2,4 – 14,2	50 x 0,6	50 x 0,6	
	80 < DN ≤ 90	2,6 – 14,2	50 x 0,6	50 x 0,6	
	90 < DN ≤ 100	2,8 – 14,2	50 x 0,6	50 x 0,6	
	100 < DN ≤ 108	3,0 – 14,2	50 x 0,6	50 x 0,6	
	108 < DN ≤ 120	3,2 – 14,2	50 x 0,6	50 x 0,6	
	120 < DN ≤ 130	3,4 – 14,2	50 x 0,6	50 x 0,6	
	130 < DN ≤ 140	3,6 – 14,2	50 x 0,6	50 x 0,6	
	140 < DN ≤ 150	3,8 – 14,2	50 x 0,6	50 x 0,6	
	150 < DN ≤ 160	4,0 – 14,2	50 x 0,6	50 x 0,6	
	160 < DN ≤ 170	4,2 – 14,2	50 x 0,6	50 x 0,6	
	170 < DN ≤ 180	4,4 – 14,2	50 x 0,6	50 x 0,6	
	180 < DN ≤ 190	4,6 – 14,2	50 x 0,6	50 x 0,6	
	190 < DN ≤ 200	4,8 – 14,2	50 x 0,6	50 x 0,6	
	200 < DN ≤ 210	5,0 – 14,2	50 x 0,6	50 x 0,6	
	210 < DN ≤ 220	5,2 – 14,2	50 x 0,6	50 x 0,6	
	220 < DN ≤ 230	5,4 – 14,2	50 x 0,6	50 x 0,6	
	230 < DN ≤ 240	5,6 – 14,2	50 x 0,6	50 x 0,6	
240 < DN ≤ 250	5,8 – 14,2	50 x 0,6	50 x 0,6		
250 < DN ≤ 260	6,0 – 14,2	50 x 0,6	50 x 0,6		
260 < DN ≤ 273	6,3 – 14,2	50 x 0,6	50 x 0,6		

PiroCoating, PiroCoat I and PiroCoat A

Penetration seals made with use of PiroCoat A
Insulated metal pipes penetration seals in rigid floor

Annex B16
of European
Technical Assessment
ETA-17/1062

Table B16. Resistance to fire classification of metal pipes with with local mineral wool insulation, length of 500 mm, width of 50 mm and density of 60 kg/m³ penetration seals with use of PiroCoat A in rigid floor, in accordance with Annex A and Annex C14 (continued).

Pipe material	Pipe diameter [mm]	Pipe wall thickness [mm]	PiroCoat A length x thickness (pipe cover) [mm]	PiroCoat A length x thickness (supporting construction cover) [mm]	Fire resistance class
Cast iron	DN ≤ 10	≥ 1,0	50 x 0,6	50 x 0,6	EI 120 - C/C EI 120 - C/U
	10 < DN ≤ 17,2	1,1 – 2,4	50 x 0,6	50 x 0,6	
	17,2 < DN ≤ 30	1,4 – 14,2	50 x 0,6	50 x 0,6	
	30 < DN ≤ 42	1,6 – 14,2	50 x 0,6	50 x 0,6	
	42 < DN ≤ 50	1,8 – 14,2	50 x 0,6	50 x 0,6	
	50 < DN ≤ 60	2,0 – 14,2	50 x 0,6	50 x 0,6	
	60 < DN ≤ 70	2,2 – 14,2	50 x 0,6	50 x 0,6	
	70 < DN ≤ 80	2,4 – 14,2	50 x 0,6	50 x 0,6	
	80 < DN ≤ 90	2,6 – 14,2	50 x 0,6	50 x 0,6	
	90 < DN ≤ 100	2,8 – 14,2	50 x 0,6	50 x 0,6	
	100 < DN ≤ 108	3,0 – 14,2	50 x 0,6	50 x 0,6	
	108 < DN ≤ 120	3,2 – 14,2	50 x 0,6	50 x 0,6	
	120 < DN ≤ 130	3,4 – 14,2	50 x 0,6	50 x 0,6	
	130 < DN ≤ 140	3,6 – 14,2	50 x 0,6	50 x 0,6	
	140 < DN ≤ 150	3,8 – 14,2	50 x 0,6	50 x 0,6	
	150 < DN ≤ 160	4,0 – 14,2	50 x 0,6	50 x 0,6	
	160 < DN ≤ 170	4,2 – 14,2	50 x 0,6	50 x 0,6	
	170 < DN ≤ 180	4,4 – 14,2	50 x 0,6	50 x 0,6	
	180 < DN ≤ 190	4,6 – 14,2	50 x 0,6	50 x 0,6	
	190 < DN ≤ 200	4,8 – 14,2	50 x 0,6	50 x 0,6	
	200 < DN ≤ 210	5,0 – 14,2	50 x 0,6	50 x 0,6	
	210 < DN ≤ 220	5,2 – 14,2	50 x 0,6	50 x 0,6	
	220 < DN ≤ 230	5,4 – 14,2	50 x 0,6	50 x 0,6	
	230 < DN ≤ 240	5,6 – 14,2	50 x 0,6	50 x 0,6	
240 < DN ≤ 250	5,8 – 14,2	50 x 0,6	50 x 0,6		
250 < DN ≤ 260	6,0 – 14,2	50 x 0,6	50 x 0,6		
260 < DN ≤ 273	6,3 – 14,2	50 x 0,6	50 x 0,6		
	274	7,0 – 14,2	50 x 0,6	50 x 0,6	EI 60 / E 120 - C/C EI 60 / E 120 - C/U

PiroCoating, PiroCoat I and PiroCoat A

Penetration seals made with use of PiroCoat A
Insulated metal pipes penetration seals in rigid floor

Annex B16
of European
Technical Assessment
ETA-17/1062

Table B17. Resistance to fire classification of metal pipes with local mineral wool insulation, length of 500 mm, width of 50 mm and density of 50 kg/m³ penetration seals with use of PiroCoat A in rigid floor, in accordance with Annex A and Annex C15.

Pipe material	Pipe diameter [mm]	Pipe wall thickness [mm]	PiroCoat A length x thickness (pipe cover) [mm]	PiroCoat A length x thickness (supporting construction cover) [mm]	Fire resistance class
Steel	DN ≤ 17,2	≥ 2,5	50 x 0,6	50 x 0,6	EI 120 - C/C EI 120 - C/U
Cast iron	DN ≤ 17,2	≥ 2,5	50 x 0,6	50 x 0,6	EI 120 - C/C EI 120 - C/U
	17,2 < DN ≤ 30	2,9 – 14,2	50 x 0,6	50 x 0,6	
	30 < DN ≤ 40	3,3 – 14,2	50 x 0,6	50 x 0,6	
	40 < DN ≤ 50	3,6 – 14,2	50 x 0,6	50 x 0,6	
	50 < DN ≤ 60	4,0 – 14,2	50 x 0,6	50 x 0,6	

PiroCoating, PiroCoat I and PiroCoat A

Penetration seals made with use of PiroCoat I
Insulated metal pipes penetration seals in rigid floor

Annex B17
of European
Technical Assessment
ETA-17/1062

Table B18. Resistance to fire classification of metal pipes without insulation penetration seals with use of PiroCoat I in rigid floor, in accordance with Annex A and Annex C16.

Pipe material	Pipe diameter [mm]	Pipe wall thickness [mm]	PiroCoat I length x thickness (pipe cover) [mm]	PiroCoat I length x thickness (supporting construction cover) [mm]	Fire resistance class
Cooper	DN ≤ 10	≥ 1,0	500 x 1,2	60 x 0,6	EI 120 - C/C EI 120 - C/U
	10 < DN ≤ 20	≥ 1,2	500 x 1,2	60 x 0,6	
	20 < DN ≤ 30	1,3 – 14,2	500 x 1,2	60 x 0,6	
	30 < DN ≤ 40	1,5 – 14,2	500 x 1,2	60 x 0,6	
	40 < DN ≤ 50	1,6 – 14,2	500 x 1,2	60 x 0,6	
	50 < DN ≤ 60	1,8 – 14,2	500 x 1,2	60 x 0,6	
	60 < DN ≤ 70	1,9 – 14,2	500 x 1,2	60 x 0,6	
	70 < DN ≤ 80	2,1 – 14,2	500 x 1,2	60 x 0,6	
	80 < DN ≤ 90	2,2 – 14,2	500 x 1,2	60 x 0,6	
	90 < DN ≤ 100	2,4 – 14,2	500 x 1,2	60 x 0,6	
	100 < DN ≤ 108	2,1 – 14,2	500 x 1,2	60 x 0,6	

PiroCoating, PiroCoat I and PiroCoat A

Penetration seals made with use of PiroCoat I
Non-insulated metal pipes penetration seals in rigid floor

Annex B18
of European
Technical Assessment
ETA-17/1062

Table B18. Resistance to fire classification of metal pipes without insulation penetration seals with use of PiroCoat I in rigid floor, in accordance with Annex A and Annex C16.

Pipe material	Pipe diameter [mm]	Pipe wall thickness [mm]	PiroCoat I length x thickness (pipe cover) [mm]	PiroCoat I length x thickness (supporting construction cover) [mm]	Fire resistance class
Steel	DN ≤ 10	≥ 1,0	500 x 1,2	60 x 0,6	EI 120 - C/C EI 120 - C/U
	10 < DN ≤ 20	≥ 1,3	500 x 1,2	60 x 0,6	
	20 < DN ≤ 30	1,6 – 14,2	500 x 1,2	60 x 0,6	
	30 < DN ≤ 40	1,8 – 14,2	500 x 1,2	60 x 0,6	
	40 < DN ≤ 50	2,2 – 14,2	500 x 1,2	60 x 0,6	
	50 < DN ≤ 60	2,5 – 14,2	500 x 1,2	60 x 0,6	
	60 < DN ≤ 70	2,8 – 14,2	500 x 1,2	60 x 0,6	
	70 < DN ≤ 80	3,1 – 14,2	500 x 1,2	60 x 0,6	
	80 < DN ≤ 90	3,4 – 14,2	500 x 1,2	60 x 0,6	
	90 < DN ≤ 100	3,7 – 14,2	500 x 1,2	60 x 0,6	
	100 < DN ≤ 108	3,9 – 14,2	500 x 1,2	60 x 0,6	
	108 < DN ≤ 120	4,3 – 14,2	500 x 1,2	60 x 0,6	
	120 < DN ≤ 130	3,9 – 14,2	500 x 1,2	60 x 0,6	
	130 < DN ≤ 140	4,9 – 14,2	500 x 1,2	60 x 0,6	
	140 < DN ≤ 150	5,2 – 14,2	500 x 1,2	60 x 0,6	
	150 < DN ≤ 160	5,5 – 14,2	500 x 1,2	60 x 0,6	
	160 < DN ≤ 170	5,8 – 14,2	500 x 1,2	60 x 0,6	
	170 < DN ≤ 180	6,1 – 14,2	500 x 1,2	60 x 0,6	
	180 < DN ≤ 190	6,4 – 14,2	500 x 1,2	60 x 0,6	
	190 < DN ≤ 200	6,7 – 14,2	500 x 1,2	60 x 0,6	
	200 < DN ≤ 210	7,0 – 14,2	500 x 1,2	60 x 0,6	
	210 < DN ≤ 220	7,3 – 14,2	500 x 1,2	60 x 0,6	
	220 < DN ≤ 230	7,6 – 14,2	500 x 1,2	60 x 0,6	
	230 < DN ≤ 240	7,9 – 14,2	500 x 1,2	60 x 0,6	
240 < DN ≤ 250	8,2 – 14,2	500 x 1,2	60 x 0,6		
250 < DN ≤ 260	8,5 – 14,2	500 x 1,2	60 x 0,6		
260 < DN ≤ 273	8,9 – 14,2	500 x 1,2	60 x 0,6		

PiroCoating, PiroCoat I and PiroCoat A

Penetration seals made with use of PiroCoat I
Non-insulated metal pipes penetration seals in rigid floor

Annex B18
of European
Technical Assessment
ETA-17/1062

Table B18. Resistance to fire classification of metal pipes without insulation penetration sealed with use of PiroCoat I in rigid floor, in accordance with Annex A and Annex C16 (continued).

Pipe material	Pipe diameter [mm]	Pipe wall thickness [mm]	PiroCoat I length x thickness (pipe cover) [mm]	PiroCoat I length x thickness (supporting construction cover) [mm]	Fire resistance class
Cast iron	DN ≤ 10	≥ 1,0	500 x 1,2	60 x 0,6	EI 120 - C/C EI 120 - C/U
	10 < DN ≤ 20	≥ 1,2	500 x 1,2	60 x 0,6	
	20 < DN ≤ 30	1,5 – 14,2	500 x 1,2	60 x 0,6	
	30 < DN ≤ 40	1,7 – 14,2	500 x 1,2	60 x 0,6	
	40 < DN ≤ 50	1,9 – 14,2	500 x 1,2	60 x 0,6	
	50 < DN ≤ 60	2,1 – 14,2	500 x 1,2	60 x 0,6	
	60 < DN ≤ 70	2,4 – 14,2	500 x 1,2	60 x 0,6	
	70 < DN ≤ 80	2,6 – 14,2	500 x 1,2	60 x 0,6	
	80 < DN ≤ 90	2,8 – 14,2	500 x 1,2	60 x 0,6	
	90 < DN ≤ 100	3,0 – 14,2	500 x 1,2	60 x 0,6	
	100 < DN ≤ 108	3,2 – 14,2	500 x 1,2	60 x 0,6	
	108 < DN ≤ 120	3,5 – 14,2	500 x 1,2	60 x 0,6	
	120 < DN ≤ 130	3,7 – 14,2	500 x 1,2	60 x 0,6	
	130 < DN ≤ 140	3,9 – 14,2	500 x 1,2	60 x 0,6	
	140 < DN ≤ 150	3,7 – 14,2	500 x 1,2	60 x 0,6	
	150 < DN ≤ 160	4,4 – 14,2	500 x 1,2	60 x 0,6	
	160 < DN ≤ 170	4,6 – 14,2	500 x 1,2	60 x 0,6	
	170 < DN ≤ 180	4,8 – 14,2	500 x 1,2	60 x 0,6	
	180 < DN ≤ 190	5,1 – 14,2	500 x 1,2	60 x 0,6	
	190 < DN ≤ 200	5,3 – 14,2	500 x 1,2	60 x 0,6	
	200 < DN ≤ 210	5,5 – 14,2	500 x 1,2	60 x 0,6	
	210 < DN ≤ 220	6,0 – 14,2	500 x 1,2	60 x 0,6	
	220 < DN ≤ 230	6,6 – 14,2	500 x 1,2	60 x 0,6	
230 < DN ≤ 240	7,1 – 14,2	500 x 1,2	60 x 0,6		
240 < DN ≤ 250	7,7 – 14,2	500 x 1,2	60 x 0,6		
250 < DN ≤ 260	8,2 – 14,2	500 x 1,2	60 x 0,6		
260 < DN ≤ 273	8,9 – 14,2	500 x 1,2	60 x 0,6		

PiroCoating, PiroCoat I and PiroCoat A

Penetration seals made with use of PiroCoat I
Non-insulated metal pipes penetration seals in rigid floor

Annex B18
of European
Technical Assessment
ETA-17/1062

Table B19. Resistance to fire classification of plastic pipes with mineral wool insulation, density of 50 kg/m³ penetration seals in rigid floor, made with use of PiroCoat I in accordance with Annex A and Annex C17.

Pipe material	Pipe diameter [mm]	Pipe wall thickness [mm]	PiroCoat I length x thickness (supporting construction cover) [mm]	Fire resistance class
PE-HD	DN ≤ 40	3,0	15,0 x 4,0	EI 120 - C/C EI 120 - C/U
PP	DN ≤ 40	1,9	15,0 x 4,0	
PVC-U	DN ≤ 40	1,9	15,0 x 4,0	

PiroCoating, PiroCoat I and PiroCoat A

Penetration seals made with use of PiroCoat I
Insulated plastic pipes penetration seals in rigid floor

Annex B19
of European
Technical Assessment
ETA-17/1062

Table B20. Resistance to fire classification of small cables ($\varnothing \leq 21$ mm) penetration seals in flexible or rigid floor thickness of $t \geq 150$ mm, made with use of PiroCoating in accordance with Annex A and Annex C18.

Fire resistance class: EI 120

PiroCoating, PiroCoat I and PiroCoat A	Annex B20 of European Technical Assessment ETA-17/1062
Penetration seals made with use of PiroCoating Cables penetration seals in rigid floor	

Table B21. Resistance to fire classification of plastic pipes with mineral wool insulation, density of min. 50 kg/m³ penetration seals in rigid floor, made with use of PiroCoat A and Piro Multitube PM dimensions of 100 x 9,6 mm (length x thickness) in accordance with Annex A and Annex C19.

Pipe material	Pipe diameter [mm]	Pipe wall thickness [mm]	Insulation thickness [mm]	PiroCoat A thickness x length (floor / service) [mm]	Fire resistance class
PP-R STABIL	DN ≤ 110	18,3	25,0	0,6 x 50 / 0,6 x 50	EI 180 - C/C EI 180 - C/U
PP-R/GF/PP-R	DN ≤ 75	10,3	30,0	0,6 x 50 / 0,6 x 50	
		18,3	25,0	0,6 x 50 / 0,6 x 50	
	75 < DN ≤ 110	18,3	25,0	0,6 x 50 / 0,6 x 50	

PiroCoating, PiroCoat I and PiroCoat A

Penetration seals made with use of PiroCoat A
Insulated plastic pipes penetration seals in rigid floor

Annex B21
of European
Technical Assessment
ETA-17/1062

Table B22. Resistance to fire classification of metal pipes with mineral wool insulation, density of 50 kg/m³ penetration seals in rigid floor, made with use of PiroCoat A in accordance with Annex A and Annex C20.

Pipe material	Pipe diameter [mm]	Pipe wall thickness [mm]	Insulation thickness [mm]	PiroCoat A thickness x length (floor / service) [mm]	Fire resistance class
Cooper	DN ≤ 50	1,0 – 14,2	30,0	0,6 x 50 / 0,6 x 50	EI 180 - C/C EI 180 - C/U
Steel	DN ≤ 160	1,0 – 14,2	30,0	0,6 x 50 / 0,6 x 50	EI 180 - C/C EI 180 - C/U

floor thickness ≥ 150 mm

PiroCoating, PiroCoat I and PiroCoat A

Penetration seals made with use of PiroCoat A
Insulated metal pipes penetration seals in rigid floor

Annex B22
of European
Technical Assessment
ETA-17/1062

Table B23. Resistance to fire classification metal pipes bundles (max. 2 copper pipes in bundles, diameter of $D1 \leq 22,2$ mm and pipe wall thickness of $t1 \geq 1,2$ mm and/or max. 2 steel pipes in bundle, diameter of $D2 \leq 17,3$ mm and pipe wall thickness of $t2 \geq 1,8$ mm) penetration seals in rigid floor thickness of $t \geq 150$ mm, made with use of PiroCoat I in accordance with Annex A and Annex C21.

Fire resistance class: EI 45 / E 180 - C/C, EI 45 / E 180 - U/C

PiroCoating, PiroCoat I and PiroCoat A

Penetration seals made with use of PiroCoating
Non-insulated metal pipes bundle penetration seals in rigid floor

Annex B23
of European
Technical Assessment
ETA-17/1062

Table B24. Resistance to fire classification plastic pipes bundles (max. 4 pipes in bundles, consisting of max. 2 x PP-R/PP-R+GF/PP-R pipes diameter of max. 20 mm and pipe wall thickness of 4,0 mm and 2 x PE-RT/AL/PE-RT pipes diameter of max. 50 mm and pipe wall thickness of 5,5 mm), with additional small cable ($\varnothing \leq 14$ mm) outside the bundle penetration seals in rigid floor thickness of $t \geq 150$ mm, made with use of PiroCoating and Piro Multitube PM dimensions of 9,6 x 100 mm in accordance with Annex A and Annex C22.

Fire resistance class: EI 180 - C/C, EI 180 - U/C

PiroCoating, PiroCoat I and PiroCoat A

Penetration seals made with use of PiroCoating
Non-insulated plastic pipes bundle penetration seals in rigid floor

Annex B24
of European
Technical Assessment
ETA-17/1062

Table B25. Resistance to fire classification of single or double copper pipe with PE foam insulation with additional small cable ($\varnothing \leq 14$ mm) outside the bundle in rigid floor, made with use of PiroCoating, PiroCoat I and Piro Multitube PM dimensions of 4,0 x 60 mm (thickness x length) in accordance with Annex A and Annex C23.

Pipe material	Single or double pipe diameter [mm]	Pipe wall thickness [mm]	Insulation thickness [mm]	Intumescent material length x thickness [mm]	Fire resistance class
Cooper	$DN \leq 6,4$	$\geq 0,8$	9,0	60 x 4,0	EI 180 - C/C EI 180 - C/U
	$6,4 < DN \leq 9,6$	$\geq 0,9$	9,0	60 x 4,0	EI 120 / E 180 - C/C EI 120 / E 180 - C/U
	$9,6 < DN \leq 22,2$	$\geq 1,0$	9,0	60 x 4,0	EI 120 / E 180 - C/C EI 120 / E 180 - C/U

PiroCoating, PiroCoat I and PiroCoat A

Penetration seals made with use of PiroCoating and PiroCoat I
Non-insulated metal pipes penetration seals in rigid floor

Annex B25
of European
Technical Assessment
ETA-17/1062

Table B26. Resistance to fire classification of steel pipes type Geberit N in rigid floor, made with use of PiroCoat I and PiroCoat A Pasta in accordance with Annex A and Annex C24.

Pipe material	Pipe diameter [mm]	Pipe wall thickness [mm]	PiroCoat I / PiroCoat A thickness x length [mm]	Fire resistance class
steel pipes type Geberit N	DN ≤ 42	1,5 – 1,9	1,2 x 500 / 0,6 x 50	EI 45 / E 180 - C/C EI 45 / E 180 - C/U
		2,0 – 14,2	1,2 x 500 / 0,6 x 50	EI 90 / E 180 - C/C
	42 < DN ≤ 108	2,0 – 14,2	1,2 x 500 / 0,6 x 50	EI 90 / E 180 - C/U

PiroCoating, PiroCoat I and PiroCoat A

Penetration seals made with use of PiroCoat I and PiroCoat A Pasta
Non-insulated metal pipes penetration seals in rigid floor

Annex B26
of European
Technical Assessment
ETA-17/1062

Table B27. Resistance to fire classification of cables in cable tray in mixed penetration seals, made with use of PiroCoating in rigid wall minimum thickness of 150 mm, in accordance with Annex A and Annex C26.

Fire resistance class: EI 120

PiroCoating, PiroCoat I and PiroCoat A	Annex B27 of European Technical Assessment ETA-17/1062
Mixed penetration seals made with use of PiroCoat I and PiroCoat A Pasta Cables in tray mixed penetration seals in rigid wall	

Table B28. Resistance to fire classification of cables in cable tray in mixed penetration seals, made with use of PiroCoating in rigid floor, in accordance with Annex A and Annex C27.

Fire resistance class: EI 120

PiroCoating, PiroCoat I and PiroCoat A	Annex B28 of European Technical Assessment ETA-17/1062
Mixed penetration seals made with use of PiroCoat I and PiroCoat A Pasta Cables in tray mixed penetration seals in rigid floor	

Table B29. Resistance to fire classification of plastic pipes with mineral wool insulation, density of min. 150 kg/m³ in mixed penetration seals in rigid wall, made with use of PiroCoat A and Piro Collar PC, in accordance with Annex A and Annex C28.

Pipe material	Pipe diameter [mm]	Pipe wall thickness [mm]	Intumescent material (of the collar)		Fire resistance class
			width [mm]	thickness [mm]	
PE-HD / PE / ABS / SAN+PVC	DN ≤ 40,0	2,4	60	2,5	EI 120 - C/C EI 120 - U/C
	DN ≤ 160,0	6,0	60	17,0	
PP	DN ≤ 40,0	2,0	60	2,5	
	DN ≤ 135,0	5,5	60	9,5	
PVC-U / PVC-C	DN ≤ 40,0	1,9	60	2,5	
	DN ≤ 160,0	7,0	60	17,0	
wall thickness ≥ 150 mm					

PiroCoating, PiroCoat I and PiroCoat A

Mixed penetration seals made with use of PiroCoat I and PiroCoat A Pasta

Insulated plastic pipes mixed penetration seals in rigid wall

Annex B29
of European
Technical Assessment
ETA-17/1062

Table B30. Resistance to fire classification of plastic pipes with mineral wool insulation, density of min. 150 kg/m³ in mixed penetration seals in rigid floor, made with use of PiroCoat A and Piro Collar PC, in accordance with Annex A and Annex C29.

Pipe material	Pipe diameter [mm]	Pipe wall thickness [mm]	Intumescent material (of the collar)		Fire resistance class
			width [mm]	thickness [mm]	
PE-HD / PE / ABS / SAN+PVC	DN ≤ 40,0	2,4	60	2,5	EI 120 - C/C EI 120 - U/C
	DN ≤ 160,0	6,0	60	17,0	
PP	DN ≤ 40,0	2,0	60	2,5	
	DN ≤ 135,0	5,5	60	9,5	
PVC-U / PVC-C	DN ≤ 40,0	1,9	60	2,5	
	DN ≤ 160,0	7,0	60	17,0	
wall thickness ≥ 150 mm					

PiroCoating, PiroCoat I and PiroCoat A

Mixed penetration seals made with use of PiroCoat A Pasta
Insulated plastic pipes mixed penetration seals in rigid floor

Annex B30
of European
Technical Assessment
ETA-17/1062

Table B31. Resistance to fire classification of metal pipes with synthetic flexible elastomeric foam insulation (FEF) in mixed penetration seals in rigid wall, made with use of PiroCoat A and Piro Collar PC, in accordance with Annex A and Annex C30.

Pipe material	Pipe diameter [mm]	Pipe wall thickness [mm]	Synthetic flexible elastomeric foam insulation (FEF) thickness [mm]	Intumescent material (of the collar)		Fire resistance class
				width [mm]	thickness [mm]	
Steel	DN ≤ 17,2	≥ 2,0	32	60	2,5	EI 120 - C/U EI 120 - U/C EI 120 - C/C
		≥ 4,0	25	60	17,0	
	17,2 < DN ≤ 108,0	4,0 – 14,2	25	60	17,0	
wall thickness ≥ 150 mm						

PiroCoating, PiroCoat I and PiroCoat A

Mixed penetration seals made with use of PiroCoat A Pasta
Insulated metal pipes mixed penetration seals in rigid wall

Annex B31
of European
Technical Assessment
ETA-17/1062

Table B32. Resistance to fire classification of metal pipes with synthetic flexible elastomeric foam insulation (FEF) in mixed penetration seals in rigid floor, made with use of PiroCoat A and Piro Collar PC, in accordance with Annex A and Annex C31.

Pipe material	Pipe diameter [mm]	Pipe wall thickness [mm]	Synthetic flexible elastomeric foam insulation (FEF) thickness [mm]	Intumescent material (of the collar)		Fire resistance class
				width [mm]	thickness [mm]	
Steel	DN ≤ 17,2	≥ 2,0	32	60	2,5	EI 120 - C/U EI 120 - U/C EI 120 - C/C
		≥ 4,0	25	60	17,0	
	17,2 < DN ≤ 108,0	4,0 – 14,2	25	60	17,0	

PiroCoating, PiroCoat I and PiroCoat A

Mixed penetration seals made with use of PiroCoat I and PiroCoat A Pasta

Insulated metal pipes mixed penetration seals in rigid floor

Annex B32
of European
Technical Assessment
ETA-17/1062

Table B33. Resistance to fire classification of metal pipes with mineral wool insulation, density of min. 40 kg/m³ in mixed penetration seals in rigid wall, made with use of PiroCoat A, in accordance with Annex A and Annex C32.

Pipe material	Pipe diameter [mm]	Pipe wall thickness [mm]	Mineral wool insulation		Fire resistance class
			length, L [mm]	thickness, w [mm]	
Cooper	D ≤ 10,0	≥ 0,8	500	50	EI 120 - C/U EI 120 - U/C EI 120 - C/C
	10 < D ≤ 20	≥ 1,0	500	50	EI 60 / E 120 - C/U EI 60 / E 120 - U/C EI 60 / E 120 - C/C
	20 < D ≤ 30	1,1 – 14,2	500	50	
	30 < D ≤ 40	1,3 – 14,2	500	50	
	40 < D ≤ 50	1,5 – 14,2	500	50	
	50 < D ≤ 60	1,7 – 14,2	500	50	
	60 < D ≤ 70	1,8 – 14,2	500	50	
	70 < D ≤ 80	2,0 – 14,2	500	50	
	80 < D ≤ 90	2,2 – 14,2	500	50	
	90 < D ≤ 100	2,4 – 14,2	500	50	
	100 < D ≤ 108	2,5 – 14,2	500	50	
Steel	D ≤ 10	≥ 0,8	500	50	EI 120 - C/U EI 120 - U/C EI 120 - C/C
	10 < D ≤ 20	≥ 1,0	500	50	
	20 < D ≤ 30	1,1 – 1,2	500	50	EI 60 / E 120 - C/U EI 60 / E 120 - U/C EI 60 / E 120 - C/C
		1,3 – 14,2	500	50	EI 120 - C/U EI 120 - U/C EI 120 - C/C
	30 < D ≤ 40	1,3 – 1,4	500	50	EI 60 / E 120 - C/U EI 60 / E 120 - U/C EI 60 / E 120 - C/C
		1,5 – 14,2	500	50	EI 120 - C/U EI 120 - U/C EI 120 - C/C
	40 < D ≤ 50	1,5 – 1,7	500	50	EI 60 / E 120 - C/U EI 60 / E 120 - U/C EI 60 / E 120 - C/C
		1,8 – 14,2	500	50	EI 120 - C/U EI 120 - U/C EI 120 - C/C
	50 < D ≤ 60	1,7 – 1,9	500	50	EI 60 / E 120 - C/U EI 60 / E 120 - U/C EI 60 / E 120 - C/C
		2,0 – 14,2	500	50	EI 120 - C/U EI 120 - U/C EI 120 - C/C
	60 < D ≤ 70	1,8 – 2,2	500	50	EI 60 / E 120 - C/U EI 60 / E 120 - U/C EI 60 / E 120 - C/C
		2,3 – 14,2	500	50	EI 120 - C/U EI 120 - U/C EI 120 - C/C

PiroCoating, PiroCoat I and PiroCoat A

Mixed penetration seals made with use of PiroCoat A Pasta
Insulated metal pipes mixed penetration seals in rigid wall

Annex B33
of European
Technical Assessment
ETA-17/1062

Table B33. Resistance to fire classification of metal pipes with mineral wool insulation, density of min. 40 kg/m³ in mixed penetration seals in rigid wall, made with use of PiroCoat A, in accordance with Annex A and Annex C32 (continued).

Pipe material	Pipe diameter [mm]	Pipe wall thickness [mm]	Mineral wool insulation		Fire resistance class	
			length, L [mm]	thickness, w [mm]		
Steel	70 < D ≤ 80	2,0 – 2,4	500	50	EI 60 / E 120 - C/U EI 60 / E 120 - U/C EI 60 / E 120 - C/C	
		2,5 – 14,2	500	50	EI 120 - C/U EI 120 - U/C EI 120 - C/C	
	80 < D ≤ 90	2,2 – 2,7	500	50	EI 60 / E 120 - C/U EI 60 / E 120 - U/C EI 60 / E 120 - C/C	
		2,8 – 14,2	500	50	EI 120 - C/U EI 120 - U/C EI 120 - C/C	
	90 < D ≤ 100	2,4 – 2,9	500	50	EI 60 / E 120 - C/U EI 60 / E 120 - U/C EI 60 / E 120 - C/C	
		3,0 – 14,2	500	50	EI 120 - C/U EI 120 - U/C EI 120 - C/C	
	100 < D ≤ 110	2,6 – 3,2	500	50	EI 60 / E 120 - C/U EI 60 / E 120 - U/C EI 60 / E 120 - C/C	
		3,3 – 14,2	500	50	EI 120 - C/U EI 120 - U/C EI 120 - C/C	
	110 < D ≤ 120	3,0 – 3,4	500	50	EI 60 / E 120 - C/U EI 60 / E 120 - U/C EI 60 / E 120 - C/C	
		3,5 – 14,2	500	50	EI 120 - C/U EI 120 - U/C EI 120 - C/C	
	120 < D ≤ 130	3,4 – 3,7	500	50	EI 60 / E 120 - C/U EI 60 / E 120 - U/C EI 60 / E 120 - C/C	
		3,8 – 14,2	500	50	EI 120 - C/U EI 120 - U/C EI 120 - C/C	
	130 < D ≤ 140	3,8 – 3,9	500	50	EI 60 / E 120 - C/U EI 60 / E 120 - U/C EI 60 / E 120 - C/C	
		4,0 – 14,2	500	50	EI 120 - C/U EI 120 - U/C EI 120 - C/C	
	140 < D ≤ 150	4,1 – 4,2	500	50	EI 60 / E 120 - C/U EI 60 / E 120 - U/C EI 60 / E 120 - C/C	
		4,3 – 14,2	500	50	EI 120 - C/U EI 120 - U/C EI 120 - C/C	
	150 < D ≤ 159	4,5 – 14,2	500	50	EI 120 - C/U EI 120 - U/C EI 120 - C/C	
	wall thickness ≥ 150 mm					

PiroCoating, PiroCoat I and PiroCoat A

Mixed penetration seals made with use of PiroCoat A Pasta
Insulated metal pipes mixed penetration seals in rigid wall

Annex B33
of European
Technical Assessment
ETA-17/1062

Table B33. Resistance to fire classification of metal pipes with mineral wool insulation, density of min. 40 kg/m³ in mixed penetration seals in rigid wall, made with use of PiroCoat A, in accordance with Annex A and Annex C32 (continued).

Pipe material	Pipe diameter [mm]	Pipe wall thickness [mm]	Mineral wool insulation		Fire resistance class
			length, L [mm]	thickness, w [mm]	
Cast iron	DN ≤ 10	≥ 0,8	500	50	EI 120 - C/U EI 120 - U/C EI 120 - C/C
	10 < DN ≤ 20	≥ 1,0	500	50	EI 60 / E 120 - C/U EI 60 / E 120 - U/C EI 60 / E 120 - C/C
	20 < DN ≤ 30	1,1	500	50	EI 120 - C/U EI 120 - U/C EI 120 - C/C
		1,2 – 14,2	500	50	EI 60 / E 120 - C/U EI 60 / E 120 - U/C EI 60 / E 120 - C/C
	30 < DN ≤ 40	1,3	500	50	EI 120 - C/U EI 120 - U/C EI 120 - C/C
		1,4 – 14,2	500	50	EI 60 / E 120 - C/U EI 60 / E 120 - U/C EI 60 / E 120 - C/C
	40 < DN ≤ 50	1,5 – 1,6	500	50	EI 120 - C/U EI 120 - U/C EI 120 - C/C
		1,7 – 14,2	500	50	EI 60 / E 120 - C/U EI 60 / E 120 - U/C EI 60 / E 120 - C/C
	50 < DN ≤ 60	1,7 – 1,8	500	50	EI 120 - C/U EI 120 - U/C EI 120 - C/C
		1,9 – 14,2	500	50	EI 60 / E 120 - C/U EI 60 / E 120 - U/C EI 60 / E 120 - C/C
	60 < DN ≤ 70	1,8 – 2,0	500	50	EI 120 - C/U EI 120 - U/C EI 120 - C/C
		2,1 – 14,2	500	50	EI 60 / E 120 - C/U EI 60 / E 120 - U/C EI 60 / E 120 - C/C
	70 < DN ≤ 80	2,0 – 2,2	500	50	EI 120 - C/U EI 120 - U/C EI 120 - C/C
		2,3 – 14,2	500	50	EI 60 / E 120 - C/U EI 60 / E 120 - U/C EI 60 / E 120 - C/C
	80 < DN ≤ 90	2,2 – 2,4	500	50	EI 120 - C/U EI 120 - U/C EI 120 - C/C
		2,5 – 14,2	500	50	EI 60 / E 120 - C/U EI 60 / E 120 - U/C EI 60 / E 120 - C/C
	90 < DN ≤ 100	2,4 – 2,6	500	50	EI 120 - C/U EI 120 - U/C EI 120 - C/C

wall thickness ≥ 150 mm

PiroCoating, PiroCoat I and PiroCoat A

Mixed penetration seals made with use of PiroCoat I and PiroCoat A Pasta

Insulated metal pipes mixed penetration seals in rigid wall

Annex B33
of European
Technical Assessment
ETA-17/1062

Table B33. Resistance to fire classification of metal pipes with mineral wool insulation, density of min. 40 kg/m³ in mixed penetration seals in rigid wall, made with use of Piro Collar PC, in accordance with Annex A and Annex C32 (continued).

Pipe material	Pipe diameter [mm]	Pipe wall thickness [mm]	Mineral wool insulation		Fire resistance class	
			length, L [mm]	thickness, w [mm]		
Cast iron	100 < D ≤ 110	2,6 – 2,8	500	50	EI 60 / E 120 - C/U EI 60 / E 120 - U/C EI 60 / E 120 - C/C	
		2,9 – 14,2	500	50	EI 120 - C/U EI 120 - U/C EI 120 - C/C	
	110 < D ≤ 120	2,8 – 3,0	500	50	EI 60 / E 120 - C/U EI 60 / E 120 - U/C EI 60 / E 120 - C/C	
		3,1 – 14,2	500	50	EI 120 - C/U EI 120 - U/C EI 120 - C/C	
	120 < D ≤ 130	3,1 – 3,3	500	50	EI 60 / E 120 - C/U EI 60 / E 120 - U/C EI 60 / E 120 - C/C	
		3,4 – 14,2	500	50	EI 120 - C/U EI 120 - U/C EI 120 - C/C	
	130 < D ≤ 140	3,4 – 3,5	500	50	EI 60 / E 120 - C/U EI 60 / E 120 - U/C EI 60 / E 120 - C/C	
		3,6 – 14,2	500	50	EI 120 - C/U EI 120 - U/C EI 120 - C/C	
	140 < D ≤ 150	3,7	500	50	EI 60 / E 120 - C/U EI 60 / E 120 - U/C EI 60 / E 120 - C/C	
		3,8 – 14,2	500	50	EI 120 - C/U EI 120 - U/C EI 120 - C/C	
	150 < D ≤ 159	4,0 – 14,2	500	50	EI 120 - C/U EI 120 - U/C EI 120 - C/C	
	wall thickness ≥ 150 mm					

PiroCoating, PiroCoat I and PiroCoat A

Mixed penetration seals made with use of PiroCoat I and PiroCoat A Pasta

Insulated metal pipes mixed penetration seals in rigid wall

Annex B33
of European
Technical Assessment
ETA-17/1062

Table B34. Resistance to fire classification of metal pipes with mineral wool insulation, density of min. 50 kg/m³ in mixed penetration seals in rigid floor, made with use of PiroCoat A, in accordance with Annex A and Annex C33.

Pipe material	Pipe diameter [mm]	Pipe wall thickness [mm]	Mineral wool insulation		Fire resistance class
			length, L [mm]	thickness, w [mm]	
Cooper	DN ≤ 10	≥ 0,8	500	50	EI 120 - C/U EI 120 - U/C EI 120 - C/C
	10 < DN ≤ 20	≥ 1,0	500	50	EI 60 / E 120 - C/U EI 60 / E 120 - U/C EI 60 / E 120 - C/C
	20 < DN ≤ 30	1,1 – 14,2	500	50	
	30 < DN ≤ 40	1,3 – 14,2	500	50	
	40 < DN ≤ 50	1,5 – 14,2	500	50	
	50 < DN ≤ 60	1,7 – 14,2	500	50	
	60 < DN ≤ 70	1,8 – 14,2	500	50	
	70 < DN ≤ 80	2,0 – 14,2	500	50	
	80 < DN ≤ 90	2,2 – 14,2	500	50	
	90 < DN ≤ 100	2,4 – 14,2	500	50	
	100 < DN ≤ 108	2,5 – 14,2	500	50	
Steel	DN ≤ 10	≥ 0,8	500	50	EI 120 - C/U EI 120 - U/C EI 120 - C/C
	10 < DN ≤ 20	≥ 1,0	500	50	
	20 < DN ≤ 30	1,1 – 1,2	500	50	EI 60 / E 120 - C/U EI 60 / E 120 - U/C EI 60 / E 120 - C/C
		1,3 – 14,2	500	50	EI 120 - C/U EI 120 - U/C EI 120 - C/C
	30 < DN ≤ 40	1,3 – 1,4	500	50	EI 60 / E 120 - C/U EI 60 / E 120 - U/C EI 60 / E 120 - C/C
		1,5 – 14,2	500	50	EI 120 - C/U EI 120 - U/C EI 120 - C/C
	40 < DN ≤ 50	1,5 – 1,7	500	50	EI 60 / E 120 - C/U EI 60 / E 120 - U/C EI 60 / E 120 - C/C
		1,8 – 14,2	500	50	EI 120 - C/U EI 120 - U/C EI 120 - C/C
	50 < DN ≤ 60	1,7 – 1,9	500	50	EI 60 / E 120 - C/U EI 60 / E 120 - U/C EI 60 / E 120 - C/C
		2,0 – 14,2	500	50	EI 120 - C/U EI 120 - U/C EI 120 - C/C

PiroCoating, PiroCoat I and PiroCoat A

Mixed penetration seals made with use of PiroCoat A Pasta
Insulated metal pipes mixed penetration seals in rigid floor

Annex B34
of European
Technical Assessment
ETA-17/1062

Table B34. Resistance to fire classification of metal pipes with mineral wool insulation, density of min. 50 kg/m³ in mixed penetration seals in rigid floor, made with use of PiroCoat A, in accordance with Annex A and Annex C33 (continued).

Pipe material	Pipe diameter [mm]	Pipe wall thickness [mm]	Mineral wool insulation		Fire resistance class
			length, L [mm]	thickness, w [mm]	
Steel	60 < DN ≤ 70	1,8 – 2,2	500	50	EI 60 / E 120 - C/U EI 60 / E 120 - U/C EI 60 / E 120 - C/C
		2,3 – 14,2	500	50	EI 120 - C/U EI 120 - U/C EI 120 - C/C
	70 < DN ≤ 80	2,0 – 2,4	500	50	EI 60 / E 120 - C/U EI 60 / E 120 - U/C EI 60 / E 120 - C/C
		2,5 – 14,2	500	50	EI 120 - C/U EI 120 - U/C EI 120 - C/C
	80 < DN ≤ 90	2,2 – 2,7	500	50	EI 60 / E 120 - C/U EI 60 / E 120 - U/C EI 60 / E 120 - C/C
		2,8 – 14,2	500	50	EI 120 - C/U EI 120 - U/C EI 120 - C/C
	90 < DN ≤ 100	2,4 – 2,9	500	50	EI 60 / E 120 - C/U EI 60 / E 120 - U/C EI 60 / E 120 - C/C
		3,0 – 14,2	500	50	EI 120 - C/U EI 120 - U/C EI 120 - C/C
	100 < DN ≤ 110	2,6 – 3,2	500	50	EI 60 / E 120 - C/U EI 60 / E 120 - U/C EI 60 / E 120 - C/C
		3,3 – 14,2	500	50	EI 120 - C/U EI 120 - U/C EI 120 - C/C
	110 < DN ≤ 120	3,0 – 3,4	500	50	EI 60 / E 120 - C/U EI 60 / E 120 - U/C EI 60 / E 120 - C/C
		3,5 – 14,2	500	50	EI 120 - C/U EI 120 - U/C EI 120 - C/C
	120 < DN ≤ 130	3,4 – 3,7	500	50	EI 60 / E 120 - C/U EI 60 / E 120 - U/C EI 60 / E 120 - C/C
		3,8 – 14,2	500	50	EI 120 - C/U EI 120 - U/C EI 120 - C/C
	130 < DN ≤ 140	3,8 – 3,9	500	50	EI 60 / E 120 C/U EI 60 / E 120 U/C EI 60 / E 120 C/C
		4,0 – 14,2	500	50	EI 120 - C/U EI 120 - U/C EI 120 - C/C

PiroCoating, PiroCoat I and PiroCoat A

Mixed penetration seals made with use of PiroCoat A Pasta
Insulated metal pipes mixed penetration seals in rigid floor

Annex B34
of European
Technical Assessment
ETA-17/1062

Table B34. Resistance to fire classification of metal pipes with mineral wool insulation, density of min. 50 kg/m³ in mixed penetration seals in rigid floor, made with use of PiroCoat A, in accordance with Annex A and Annex C33 (continued).

Pipe material	Pipe diameter [mm]	Pipe wall thickness [mm]	Mineral wool insulation		Fire resistance class
			length, L [mm]	thickness, w [mm]	
Steel	140 < DN ≤ 150	4,1 – 4,2	500	50	EI 60 / E 120 - C/U EI 60 / E 120 - U/C EI 60 / E 120 - C/C
		4,3 – 14,2	500	50	EI 120 - C/U EI 120 - U/C EI 120 - C/C
	150 < DN ≤ 159	4,5 – 14,2	500	50	
Cast iron	DN ≤ 10	≥ 0,8	500	50	
	10 < DN ≤ 20	≥ 1,0	500	50	
	20 < DN ≤ 30	1,1	500	50	EI 60 / E 120 - C/U EI 60 / E 120 - U/C EI 60 / E 120 - C/C
		1,2 – 14,2	500	50	EI 120 - C/U EI 120 - U/C EI 120 - C/C
	30 < DN ≤ 40	1,3	500	50	EI 60 / E 120 - C/U EI 60 / E 120 - U/C EI 60 / E 120 - C/C
		1,4 – 14,2	500	50	EI 120 - C/U EI 120 - U/C EI 120 - C/C
	40 < DN ≤ 50	1,5 – 1,6	500	50	EI 60 / E 120 - C/U EI 60 / E 120 - U/C EI 60 / E 120 - C/C
		1,7 – 14,2	500	50	EI 120 - C/U EI 120 - U/C EI 120 - C/C
	50 < DN ≤ 60	1,7 – 1,8	500	50	EI 60 / E 120 - C/U EI 60 / E 120 - U/C EI 60 / E 120 - C/C
		1,9 – 14,2	500	50	EI 120 - C/U EI 120 - U/C EI 120 - C/C
	60 < DN ≤ 70	1,8 – 2,0	500	50	EI 60 / E 120 - C/U EI 60 / E 120 - U/C EI 60 / E 120 - C/C
		2,1 – 14,2	500	50	EI 120 - C/U EI 120 - U/C EI 120 - C/C
	70 < DN ≤ 80	2,0 – 2,2	500	50	EI 60 / E 120 - C/U EI 60 / E 120 - U/C EI 60 / E 120 - C/C
		2,3 – 14,2	500	50	EI 120 - C/U EI 120 - U/C EI 120 - C/C
	80 < DN ≤ 90	2,2 – 2,4	500	50	EI 60 / E 120 - C/U EI 60 / E 120 - U/C EI 60 / E 120 - C/C
2,5 – 14,2		500	50	EI 120 - C/U EI 120 - U/C EI 120 - C/C	

PiroCoating, PiroCoat I and PiroCoat A

Mixed penetration seals made with use of PiroCoat A Pasta
Insulated metal pipes mixed penetration seals in rigid floor

Annex B34
of European
Technical Assessment
ETA-17/1062

Table B34. Resistance to fire classification of metal pipes with mineral wool insulation, density of min. 50 kg/m³ in mixed penetration seals in rigid floor, made with use of PiroCoat A, in accordance with Annex A and Annex C33 (continued).

Pipe material	Pipe diameter [mm]	Pipe wall thickness [mm]	Mineral wool insulation		Fire resistance class
			length, L [mm]	thickness, w [mm]	
Cast iron	90 < DN ≤ 100	2,4 – 2,6	500	50	EI 60 / E 120 - C/U EI 60 / E 120 - U/C EI 60 / E 120 - C/C
		2,7 – 14,2	500	50	EI 120 - C/U EI 120 - U/C EI 120 - C/C
	100 < DN ≤ 110	2,6 – 2,8	500	50	EI 60 / E 120 - C/U EI 60 / E 120 - U/C EI 60 / E 120 - C/C
		2,9 – 14,2	500	50	EI 120 - C/U EI 120 - U/C EI 120 - C/C
	110 < DN ≤ 120	2,8 – 3,0	500	50	EI 60 / E 120 - C/U EI 60 / E 120 - U/C EI 60 / E 120 - C/C
		3,1 – 14,2	500	50	EI 120 - C/U EI 120 - U/C EI 120 - C/C
	120 < DN ≤ 130	3,1 – 3,3	500	50	EI 60 / E 120 - C/U EI 60 / E 120 - U/C EI 60 / E 120 - C/C
		3,4 – 14,2	500	50	EI 120 - C/U EI 120 - U/C EI 120 - C/C
	130 < DN ≤ 140	3,4 – 3,5	500	50	EI 60 / E 120 - C/U EI 60 / E 120 - U/C EI 60 / E 120 - C/C
		3,6 – 14,2	500	50	EI 120 - C/U EI 120 - U/C EI 120 - C/C
	140 < DN ≤ 150	3,7	500	50	EI 60 / E 120 - C/U EI 60 / E 120 - U/C EI 60 / E 120 - C/C
		3,8 – 14,2	500	50	EI 120 - C/U EI 120 - U/C EI 120 - C/C
	150 < DN ≤ 159	4,0 – 14,2	500	50	EI 120 - C/U EI 120 - U/C EI 120 - C/C

PiroCoating, PiroCoat I and PiroCoat A

Mixed penetration seals made with use of PiroCoat A Pasta
Insulated metal pipes mixed penetration seals in rigid floor

Annex B34
of European
Technical Assessment
ETA-17/1062

Table B35. Resistance to fire classification of metal pipes in mixed penetration seals in rigid floor, made with use of PiroCoat I, in accordance with Annex A and Annex C34.

Pipe material	Pipe diameter [mm]	Pipe wall thickness [mm]	PiroCoat I		Fire resistance class
			length, L [mm]	length, L [mm]	
Steel	DN ≤ 273	6,0 – 14,2	500	1,2	EI 60 / E 120 - C/U EI 60 / E 120 - U/C EI 60 / E 120 - C/C

PiroCoating, PiroCoat I and PiroCoat A

Mixed penetration seals made with use of PiroCoat I
Non-insulated metal pipes mixed penetration seals in rigid floor

Annex B35
of European
Technical Assessment
ETA-17/1062

Fig C1. Metal pipes penetration seal in flexible wall, made with use of PiroCoat A (with continuous mineral wool insulation)

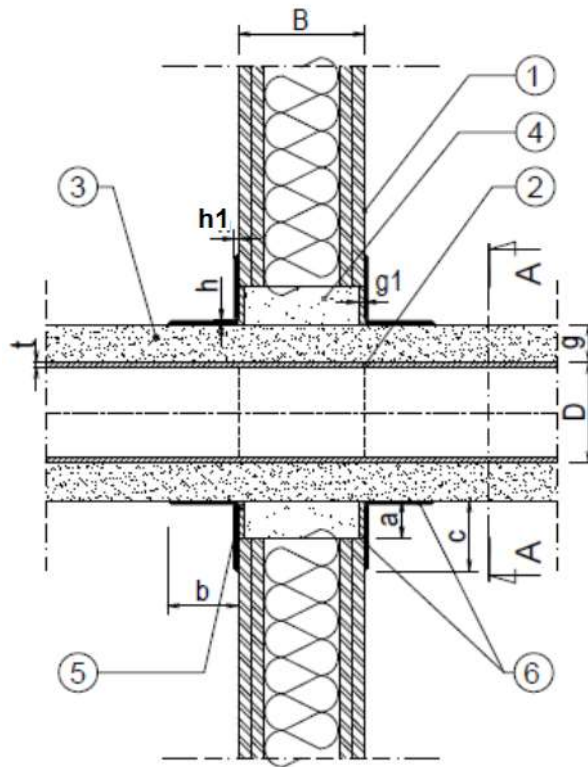

- 1 Flexible or rigid wall supporting construction thickness of min. 100 mm
- 2 Metal pipe, diameter of "D" and pipe wall thickness of "t"
- 3 Mineral wool density of min. 80 kg/m³ and thickness of g = 30 mm (continuous insulation)
- 4 Gap between the pipe insulation and supporting construction, maximum width of a = 30 mm, filled with mineral wool density of min. 50 kg/m³
- 5 Gypsum mortar minimum thickness of g1 = 5 mm
- 6 PiroCoat A, dimensions of: b = min. 50 mm and h = min. 0,6 mm (on the pipe insulation); c = min. 50 mm and h1 = min. 0,6 mm (ring on the wall around the penetration seal)

PiroCoating, PiroCoat I and PiroCoat A

Construction details

Insulated metal pipes penetration seals in flexible wall

Annex C1
of European
Technical Assessment
ETA-17/1062

Fig. C2. Metal pipes penetration seals in rigid wall, made with use of PiroCoat A (with continuous mineral wool insulation).

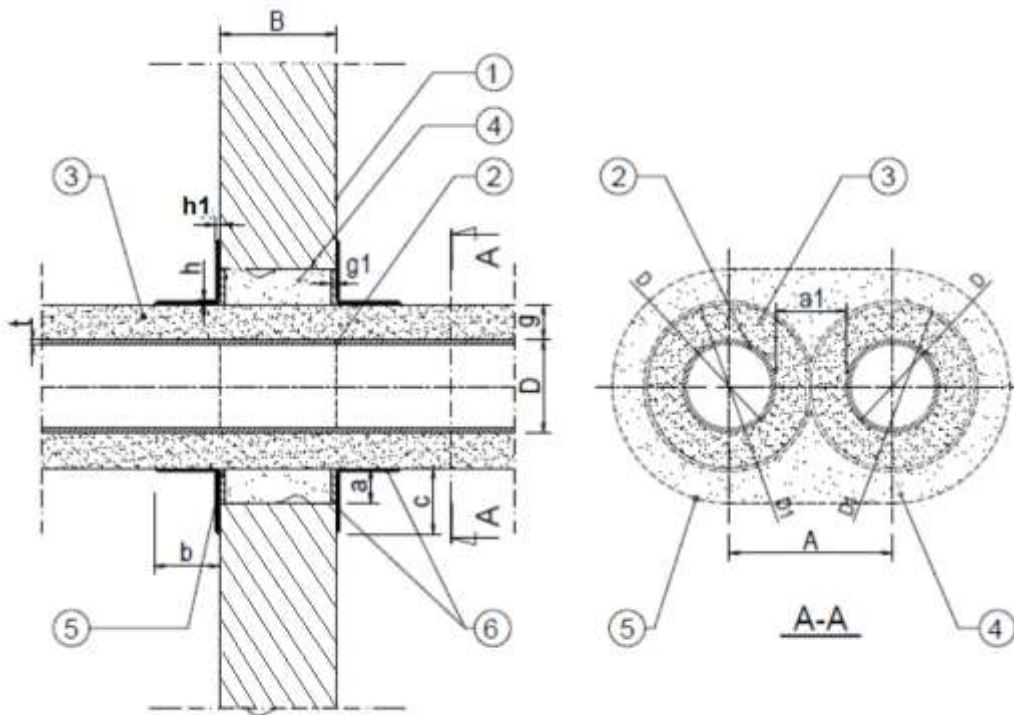

- 1 Rigid wall supporting construction thickness of min. 100 mm
- 2 Metal pipe, diameter of "D" and pipe wall thickness of "t"
- 3 Mineral wool density of min. 80 kg/m³ and thickness of g = 30 mm (continuous insulation)
- 4 Gap between the pipe insulation and supporting construction, maximum width of a = 30 mm, filled with mineral wool density of min. 50 kg/m³
- 5 Gypsum mortar minimum thickness of g1 = 5 mm
- 6 PiroCoat A, dimensions of: b = min. 50 mm and h = min. 0,6 mm (on the pipe insulation); c = min. 50 mm and h1 = min. 0,6 mm (ring on the supporting construction around the penetration seal)

PiroCoating, PiroCoat I and PiroCoat A

Construction details
Insulated metal pipes penetration seals in rigid wall

Annex C2
of European
Technical Assessment
ETA-17/1062

Fig. C3. Metal pipes bundles (max. 4 pipes in bundle) penetration seals in flexible or rigid wall, made with use of PiroCoat A (with continuous mineral wool insulation).

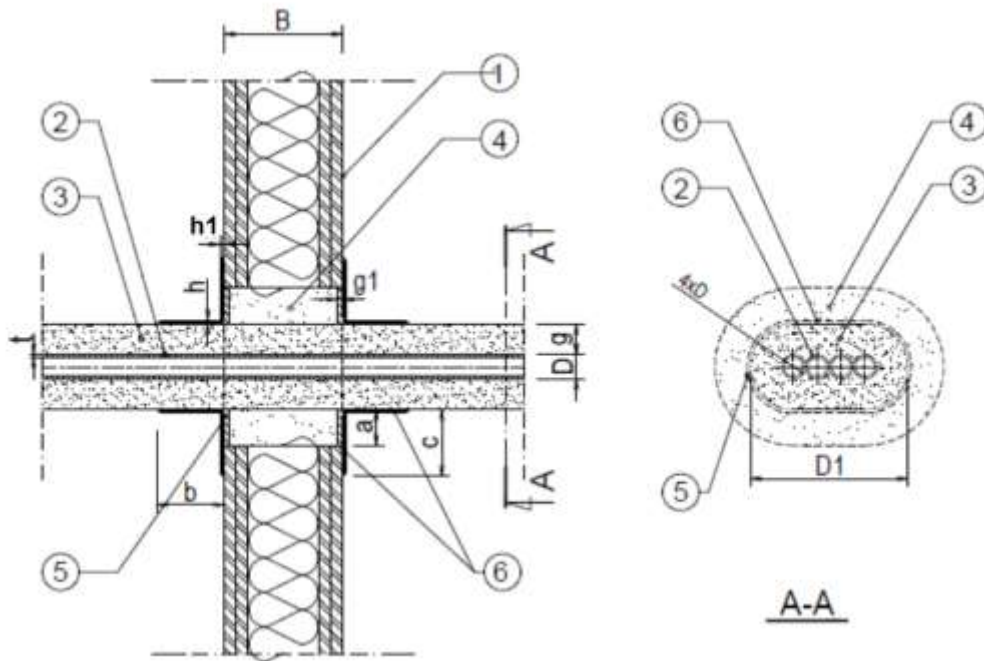

- 1 Flexible or rigid wall supporting construction thickness of min. 100 mm
- 2 Metal pipe, diameter of "D" and pipe wall thickness of "t"
- 3 Mineral wool density of min. 50 kg/m³ and thickness of g = 30 mm (continuous insulation)
- 4 Gap between the pipe insulation and supporting construction, maximum width of a = 30 mm, filled with mineral wool density of min. 50 kg/m³
- 5 Gypsum mortar minimum thickness of g1 = 5 mm
- 6 PiroCoat A, dimensions of: b = min. 50 mm and h = min. 0,6 mm (on the pipe insulation); c = min. 50 mm and h1 = min. 0,6 mm (ring on the supporting construction around the penetration seal)

PiroCoating, PiroCoat I and PiroCoat A

Construction details

Insulated metal pipes bundle penetration seals in flexible or rigid wall

Annex C3
of European
Technical Assessment
ETA-17/1062

Fig. C4. Metal pipes penetration seals in flexible or rigid wall, made with use of PiroCoat A (with local mineral wool insulation).

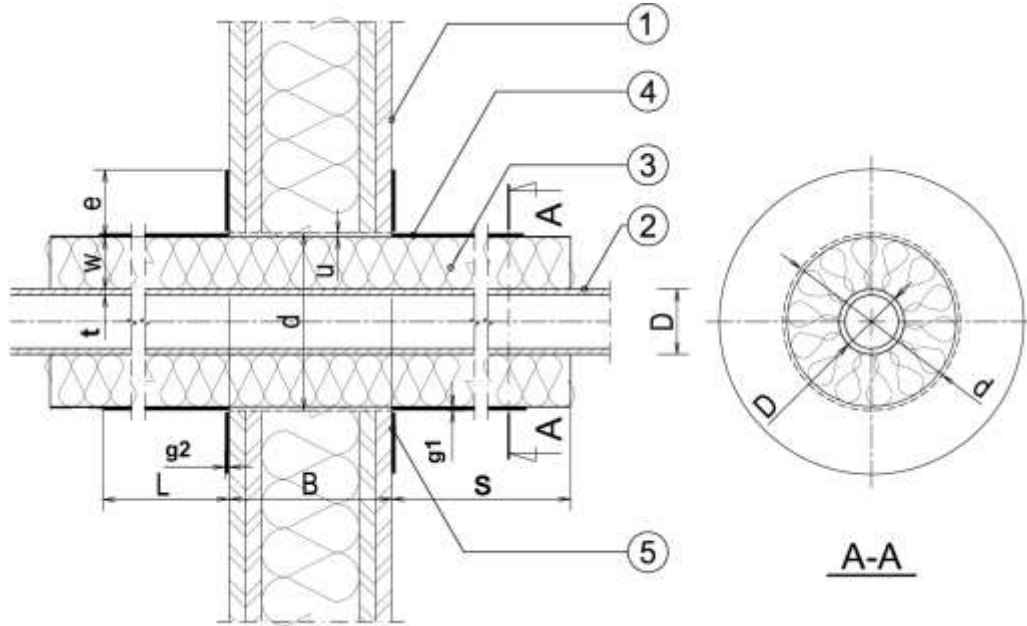

- 1 Flexible or rigid wall supporting construction thickness of min. 125 mm
- 2 Metal pipe, diameter of "D" and pipe wall thickness of "t"
- 3 Mineral wool density of min. 60 kg/m³; length of L = min. 500 mm; thickness of min. 50 mm for steel and copper pipes and min. 40 mm for steel Spiro pipes
- 4 PiroCoat A (pipe insulation cover), length of L = min. 50 mm, thickness of g1 = min. 0,6 mm
- 5 PiroCoat A (ring on the wall around the penetration seal), length of e = min. 50 mm, thickness of g2 = min. 0,6 mm

Note:

Gap between the pipe insulation and supporting construction, maximum width of u = 30 mm, filled with gypsum mortar or mineral wool density of min. 50 kg/m³ and closed by means on gypsum mortar minimum thickness of g1 = 5 mm

PiroCoating, PiroCoat I and PiroCoat A

Construction details

Insulated metal pipes penetration seals in flexible or rigid wall

Annex C4
of European
Technical Assessment
ETA-17/1062

Fig. C5. Metal pipes penetration seals in rigid wall, made with use of PiroCoat A (with local mineral wool insulation).

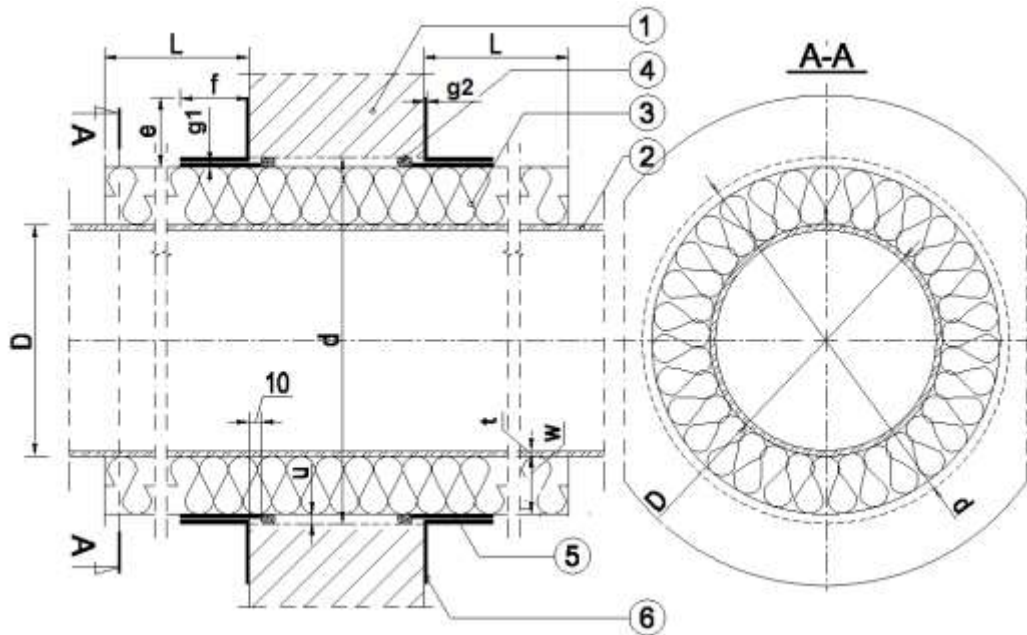

- 1 Rigid wall supporting construction thickness of min. 150 mm
- 2 Metal pipe, diameter of "D" and pipe wall thickness of "t";
- 3 Mineral wool length of L = min. 500 mm, thickness of min. 50 mm; density of min. 70 kg/m³ for copper and cast iron pipes and min. 80 kg/m³ for steel Spiro pipes
- 4 Gap between the pipe insulation and supporting construction filled with or mineral wool density of min. 50 kg/m³ or cement mortar, maximum width of u = 30 mm
- 5 PiroCoat A (pipe insulation cover), length of f = min. 60 mm, thickness of g1 = min. 0,6 mm
- 6 PiroCoat A (ring on the wall around the penetration seal), length of e = min. 50 mm, thickness of g2 = min. 0,6 mm

PiroCoating, PiroCoat I and PiroCoat A

Construction details
Insulated metal pipes penetration seals in rigid wall

Annex C5
of European
Technical Assessment
ETA-17/1062

Fig. C6. Metal pipes penetration seals in flexible wall, made with use of PiroCoat I (without insulation).

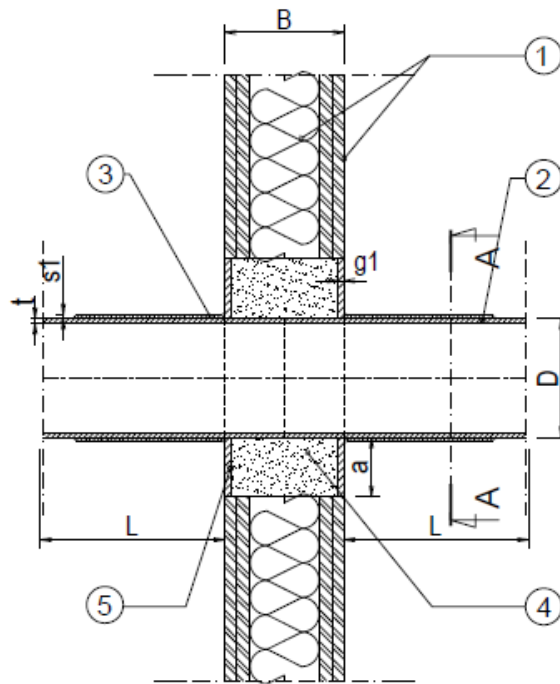

- 1 Flexible wall supporting construction thickness of min. 100 mm
- 2 Metal pipe, diameter of "D" and pipe wall thickness of "t"
- 3 PiroCoat I, dimensions of: length L = min. 500 mm, thickness s1 = min. 1,2 mm, PiroCoat I additionally placed on the length of g1 = min. 5 mm, inside the supporting construction
- 4 Gap between the pipe and supporting construction, maximum width of a = 30 mm, filled with mineral wool density of min. 50 kg/m³
- 5 Gypsum mortar minimum thickness of g1 = 5 mm

PiroCoating, PiroCoat I and PiroCoat A

Construction details

Non-insulated metal pipes penetration seals in flexible wall

Annex C6
of European
Technical Assessment
ETA-17/1062

Fig. C7. Metal pipes penetration seals in rigid wall, made with use of PiroCoat I (without insulation).

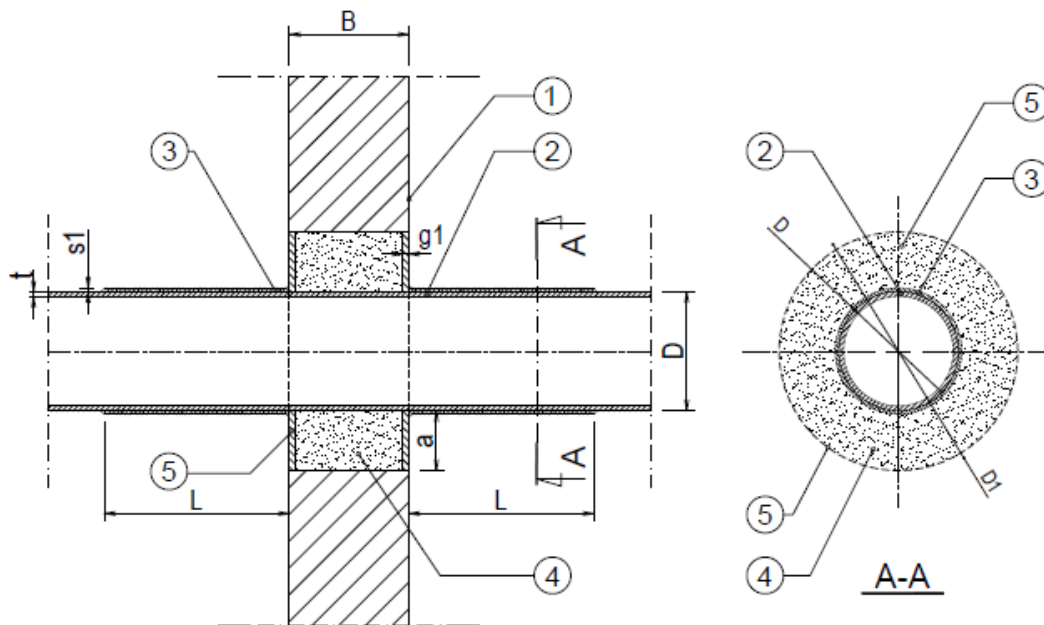

- 1 Rigid wall supporting construction thickness of min. 100 mm
- 2 Metal pipe, diameter of "D" and pipe wall thickness of "t"
- 3 PiroCoat I, dimensions of: length L = min. 500 mm, thickness s1 = min. 1,2 mm, PiroCoat I additionally placed on the length of g1 = min. 5 mm, inside the supporting construction
- 4 Gap between the pipe insulation and supporting construction, maximum width of a = 30 mm, filled with mineral wool density of min. 50 kg/m³
- 5 Gypsum mortar minimum thickness of g1 = 5 mm

PiroCoating, PiroCoat I and PiroCoat A

Construction details

Non-insulated metal and plastic pipes penetration seals in rigid wall

Annex C7
of European
Technical Assessment
ETA-17/1062

Fig. C8. Metal or plastic pipes penetration seals in rigid wall, made with use of PiroCoat I (without insulation).

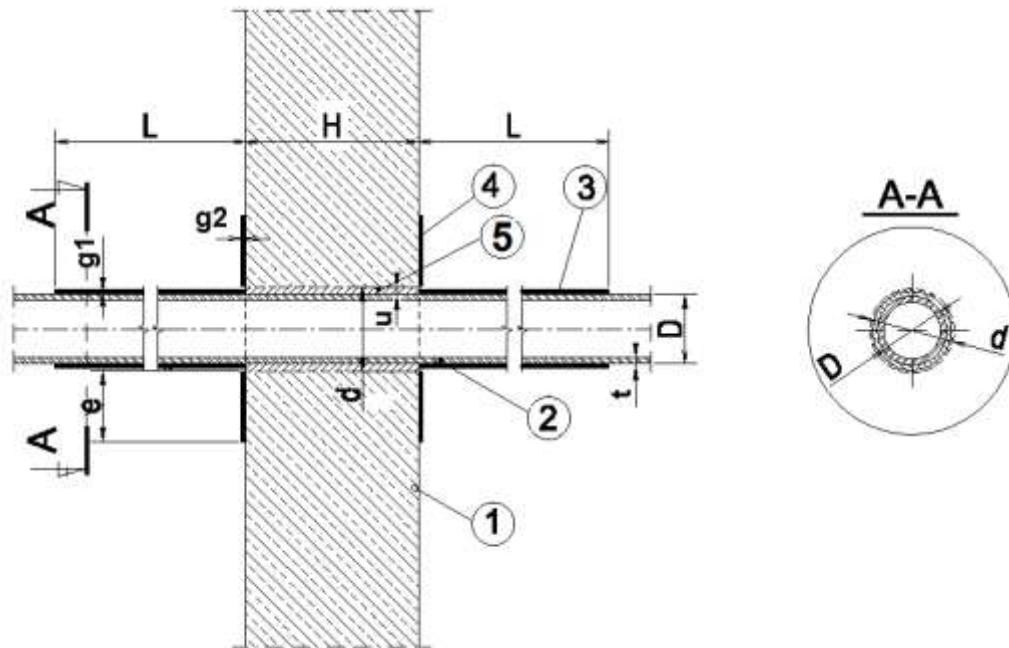

- 1 Rigid wall supporting construction thickness of min. 150 mm
- 2 Metal or plastic pipe; diameter of "D" and pipe wall thickness of "t"
- 3 PiroCoat I (pipe cover), length of L = min. 500 mm, thickness of g1 = min. 1,2 mm
- 4 PiroCoat I (ring on the floor around the penetration seal), length of e = min. 50 mm, thickness of g2 = min. 0,6 mm
- 5 Gap between the pipe and supporting construction filled with mineral wool density of min. 50 kg/m³ or cement mortar, maximum width of u = 30 mm

PiroCoating, PiroCoat I and PiroCoat A

Construction details

Non-insulated metal or plastic pipes penetration seals in rigid wall

Annex C8
of European
Technical Assessment
ETA-17/1062

Fig. C9. Metal or plastic pipes, penetration seals in rigid wall, made with use of PiroCoat I (with continuous mineral wool insulation).

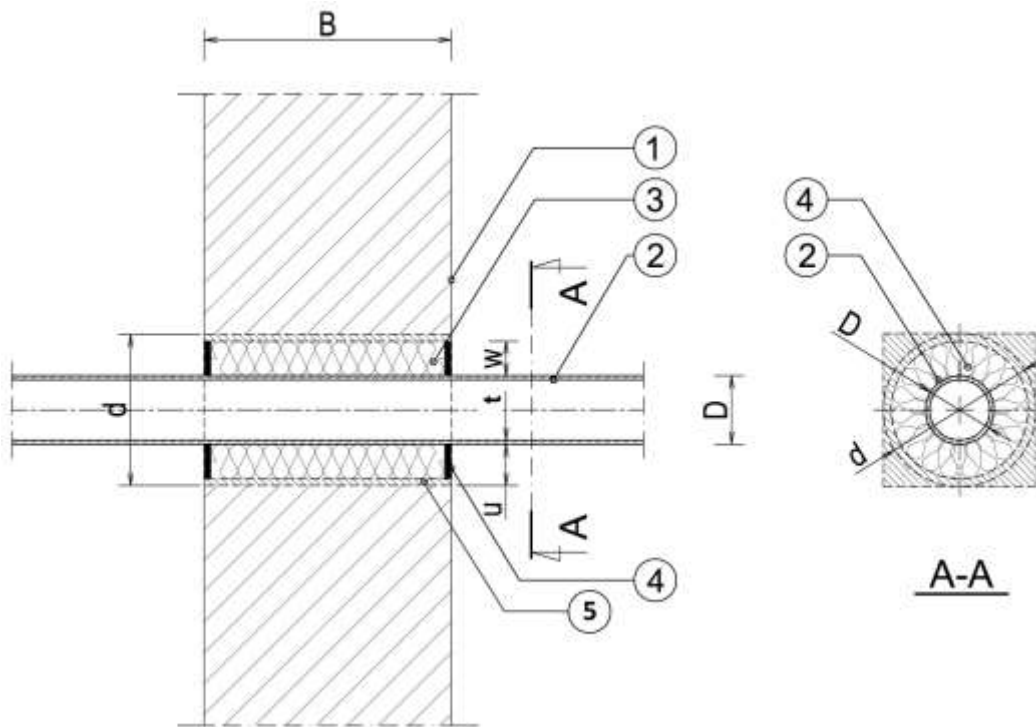

- 1 Rigid wall thickness of min. 150 mm
- 2 Plastic pipe in accordance with table C1
- 3 Mineral wool, density of 50 kg/m³, thickness of w = min. 15 mm
- 4 PiroCoat I, thickness of min. 4 mm
- 5 Gap between the mineral wool and supporting construction filled with cement mortar, thickness of max. 17,5 mm

Table C1

Pipe material	Pipe diameter, D [mm]	Pipe wall thickness, t[mm]	Opening max. diameter, d [mm]	Min. thickness of mineral wool / min. length of PiroCoat I, w [mm]	Min. thickness of PiroCoat I, g [mm]
PE-HD	≤ 40	2,4	85	15	4
PP	≤ 40	1,8	85	15	4
PVC	≤ 40	1,9	85	15	4

PiroCoating, PiroCoat I and PiroCoat A

Construction details
Insulated plastic pipes penetration seals in rigid wall

Annex C9
of European
Technical Assessment
ETA-17/1062

Fig. C10. Metal pipes penetration seals in rigid wall, made with use of PiroCoat I and Piro Multitube PM width of 100 mm and thickness 4,8 mm (with PE foam insulation).

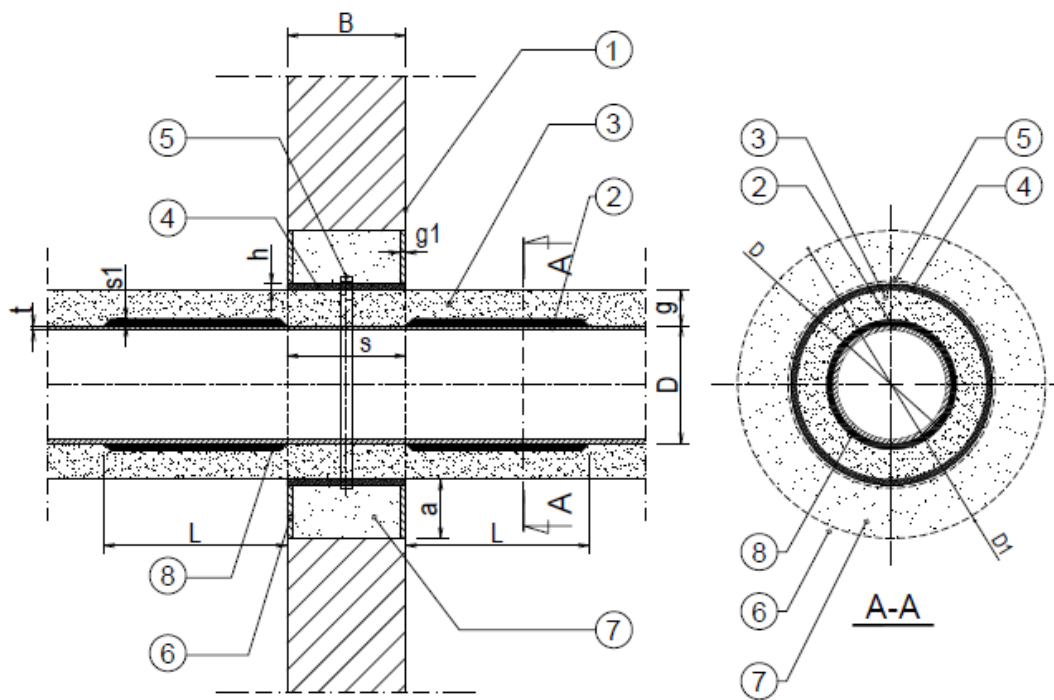

- 1 Rigid wall supporting construction thickness of $B = \text{min. } 100 \text{ mm}$
- 2 Metal pipe, diameter of "D" and pipe wall thickness of "t"
- 3 PE foam continuous insulation, thickness of $g = 32 \text{ mm}$; nominal density of 30 kg/m^3 and reaction to fire class E in accordance with EN 13501-1
- 4 Piro Multitube PM dimensions of $[h \times s]$, placed centrally inside the wall
- 5 Electrically clamped band
- 6 Gypsum mortar thickness of $g_1 = \text{min. } 5 \text{ mm}$
- 7 Gap between the pipe insulation and supporting construction, maximum width of $a = 30 \text{ mm}$, filled with mineral wool density of $\text{min. } 50 \text{ kg/m}^3$
- 8 PiroCoat I, dimensions of: length $L = \text{min. } 500 \text{ mm}$, thickness $s_1 = \text{min. } 1,2 \text{ mm}$

PiroCoating, PiroCoat I and PiroCoat A

Construction details
Insulated metal pipes penetration seals in rigid wall

Annex C10
of European
Technical Assessment
ETA-17/1062

Fig. C11. Small cables ($\varnothing \leq 21$ mm) penetration seals in rigid wall thickness of $t \geq 125$ mm, made with use of PiroCoating.

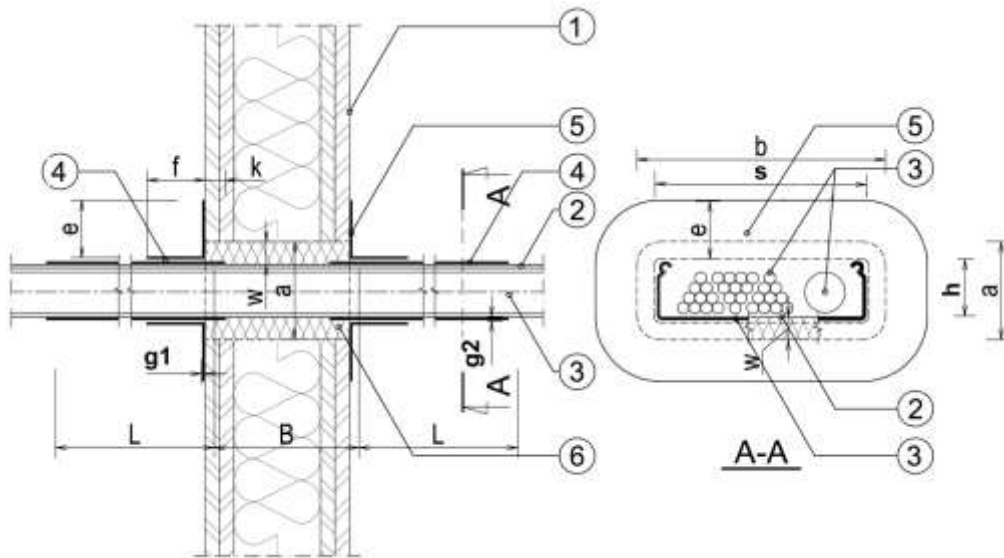

- 1 Flexible or rigid wall supporting construction thickness of min. 125 mm
- 2 Cable tray
- 3 Cables diameter of max 21 mm
- 4 PiroCoating; both sides of the wall, length of $L = \text{min. } 300$ mm, depth of $k = \text{min. } 30$ mm, thickness of $g2 = \text{min. } 1,2$ mm
- 5 PiroCoating, both sides of the wall, dimensions: $f = \text{min. } 50$ mm, $e = \text{min. } 50$ mm, $g1 = \text{min. } 0,6$ mm
- 6 Mineral wool, density of min. 50 kg/m^3 , thickness of $w = \text{max. } 40$ mm

PiroCoating, PiroCoat I and PiroCoat A

Construction details
Cables penetration seals in flexible or rigid wall

Annex C11
of European
Technical Assessment
ETA-17/1062

Fig. C12. Small cables ($\varnothing \leq 13$ mm) penetration seals in flexible or rigid wall thickness of $t \geq 100$ mm, made with use of PiroCoating.

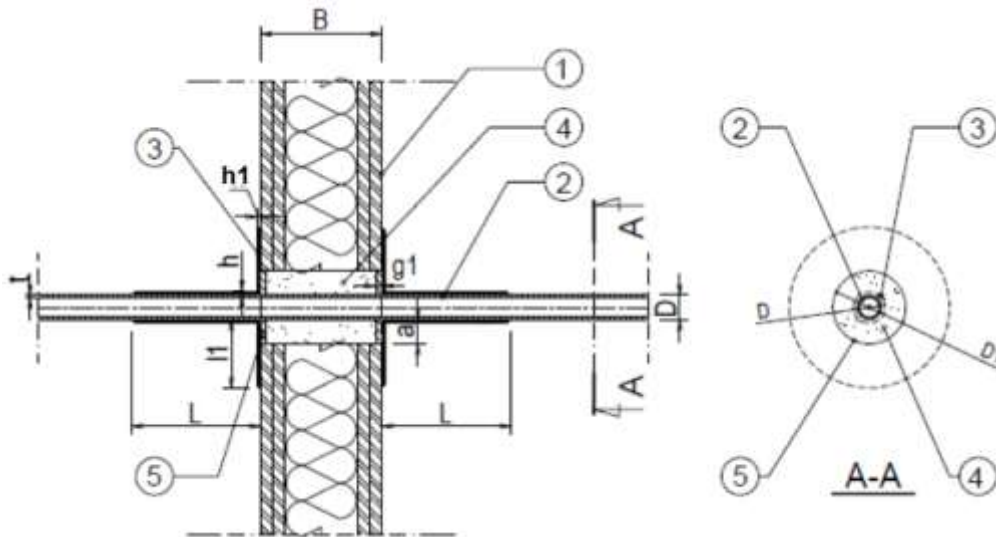

- 1 Flexible or rigid wall supporting construction thickness of min. 100 mm
- 2 Single cable diameter of max. 13 mm
- 3 PiroCoating dimensions of: length $L = \text{min. } 300$ mm, thickness $h = \text{min. } 1,2$ mm, length $l_1 = \text{min. } 50$ mm, thickness $h_1 = \text{min. } 0,6$ mm
- 4 Gap between the pipe insulation and supporting construction, maximum width of $a = 30$ mm, filled with mineral wool density of min. 50 kg/m^3
- 5 Gypsum mortar minimum thickness of $g_1 = 5$ mm

PiroCoating, PiroCoat I and PiroCoat A

Construction details
Cables penetration seals in flexible or rigid wall

Annex C12
of European
Technical Assessment
ETA-17/1062

Fig. C13. Metal pipes penetration sealed with use of Piro Multitube PM width of 100 mm and thickness of 4,8 mm with additional single small cable ($\varnothing \leq 13$ mm) penetration sealed with use of PiroCoating in rigid wall (with continuous flexible elastomeric foam (FEF) insulation).

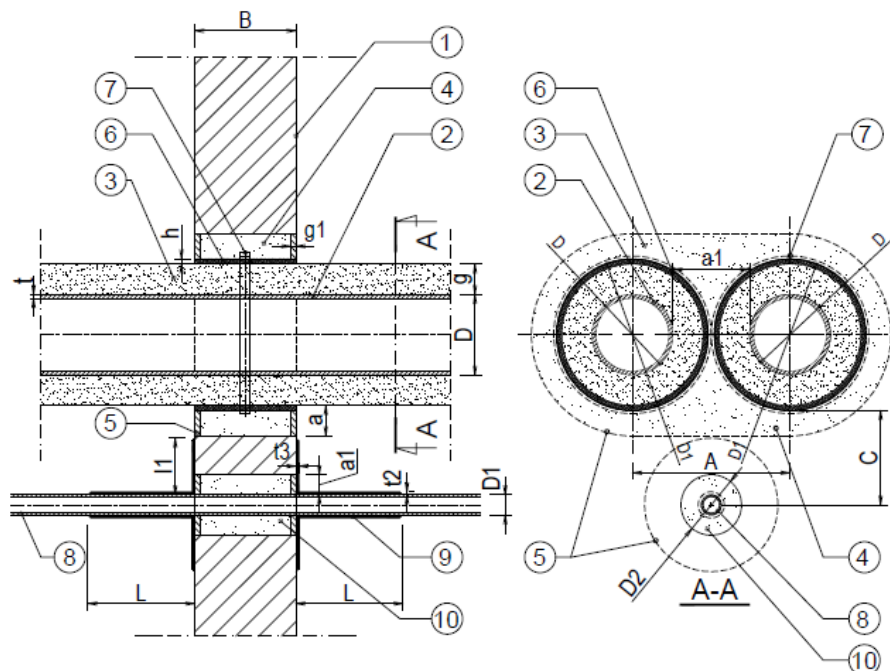

- 1 Rigid wall supporting construction thickness of min. 100 mm
- 2 Metal pipe, diameter of "D" and pipe wall thickness of "t"
- 3 Flexible elastomeric foam (FEF) continuous insulation, thickness of $g = 32$ mm, nominal density of $45 - 70 \text{ kg/m}^3$ and reaction to fire class B_L-s2 , d_0 in accordance with EN 13501-1
- 4 Gap between the pipe insulation and supporting construction, maximum width of $a = 30$ mm, filled with mineral wool density of min. 50 kg/m^3
- 5 Gypsum mortar minimum thickness of $g1 = 5$ mm
- 6 Piro Multitube PM dimensions of $[h \times s]$, placed centrally inside the wall
- 7 Electrically clamped band
- 8 Single cable diameter of max. 13 mm, placed in the distance of min. 50 mm from the Piro Multitube PM
- 9 PiroCoating dimensions of: length $L = \text{min. } 300$ mm, thickness $t2 = \text{min. } 1,2$ mm, length $l1 = \text{min. } 50$ mm, thickness $t3 = \text{min. } 0,6$ mm
- 10 Gap between the pipe insulation and supporting construction, maximum width of $a1 = 30$ mm, filled with mineral wool density of min. 50 kg/m^3

PiroCoating, PiroCoat I and PiroCoat A

Construction details
Insulated metal pipes penetration seals in rigid wall

Annex C13
of European
Technical Assessment
ETA-17/1062

Fig. C14. Metal pipes penetration seals with use of PiroCoat A in rigid floor (with local mineral wool insulation).

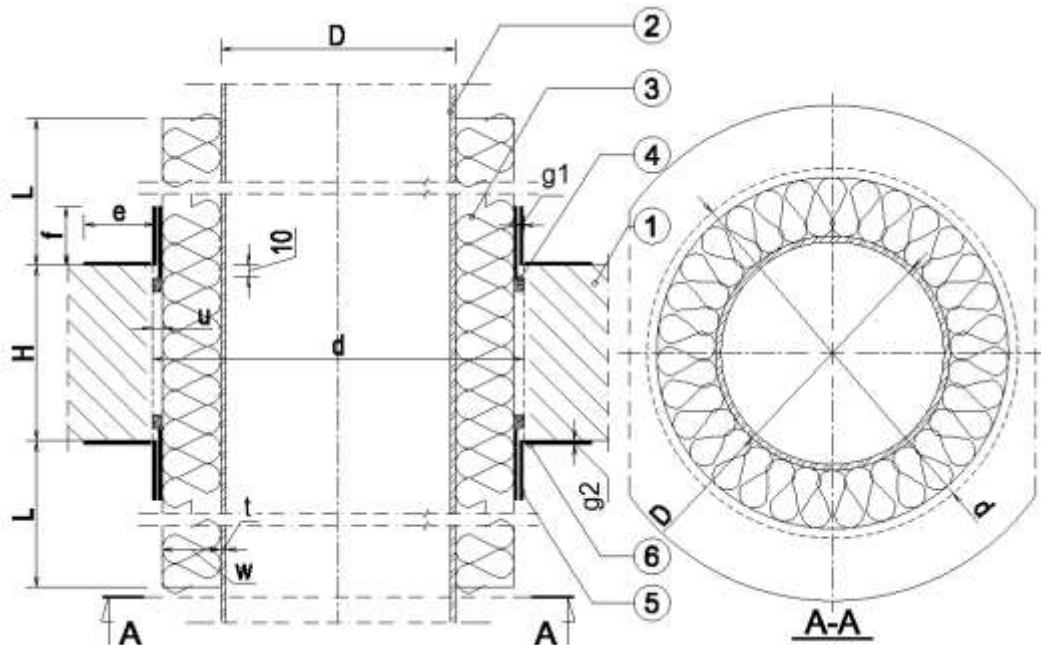

- 1 Floor supporting construction thickness of min. 150 mm
- 2 Metal pipe, diameter of "D" and pipe wall thickness of "t"
- 3 Mineral wool thickness of min. 50 mm; length of L = min. 500 mm
- 4 Gap between the pipe insulation and supporting construction (u = max. 40 mm) filled with cement mortar or mineral wool density of min. 50 kg/m³, 60 kg/m³ or 70 kg/m³ (local insulation)
- 5 PiroCoat A, dimensions: f = min. 50 mm, g1 = min. 0,6 mm

PiroCoating, PiroCoat I and PiroCoat A

Construction details
Insulated metal pipes penetration seals in rigid floor

Annex C14
of European
Technical Assessment
ETA-17/1062

Fig. C15. Metal pipes penetration seals with use of PiroCoat A in rigid floor (with local mineral wool insulation).

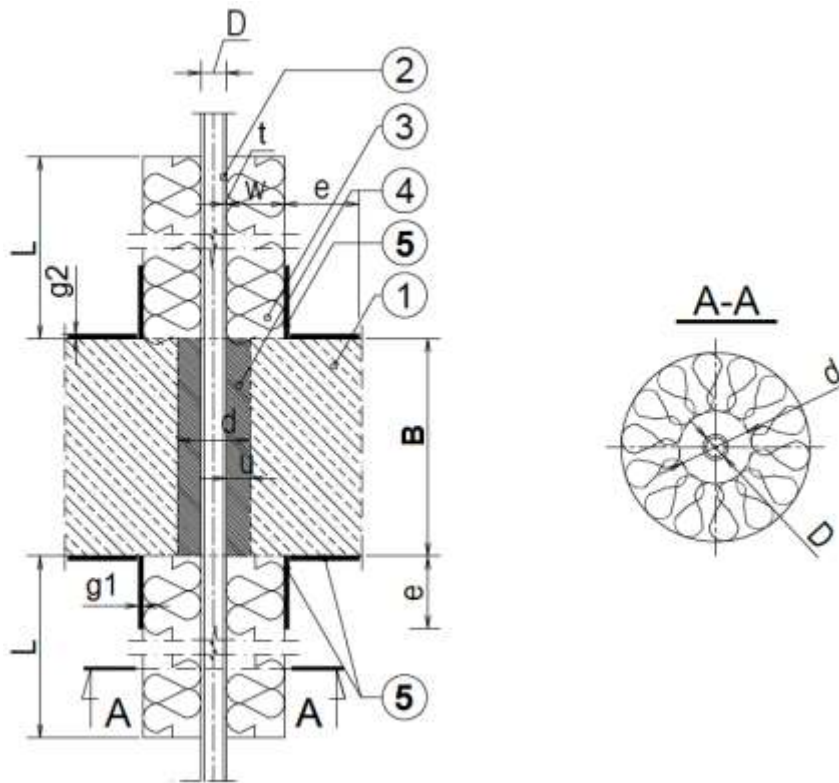

- 1 Floor supporting construction thickness of min. 150 mm
- 2 Metal pipe, diameter of "D" and pipe wall thickness of "t"
- 3 Mineral wool density of 50 kg/m³, thickness of min. 50 mm, length of min. 500 mm (local insulation)
- 4 Gap between the pipe and supporting construction filled with cement mortar, thickness of u = max. 10 mm
- 5 PiroCoat A, dimensions: e = min. 50 mm, g1 = min. 0,6 mm, g2 = min. 0,6 mm

PiroCoating, PiroCoat I and PiroCoat A

Construction details
Insulated metal pipes penetration seals in rigid floor

Annex C15
of European
Technical Assessment
ETA-17/1062

Fig. C16. Metal pipes penetration seals with use of PiroCoat I in rigid floor (without insulation).

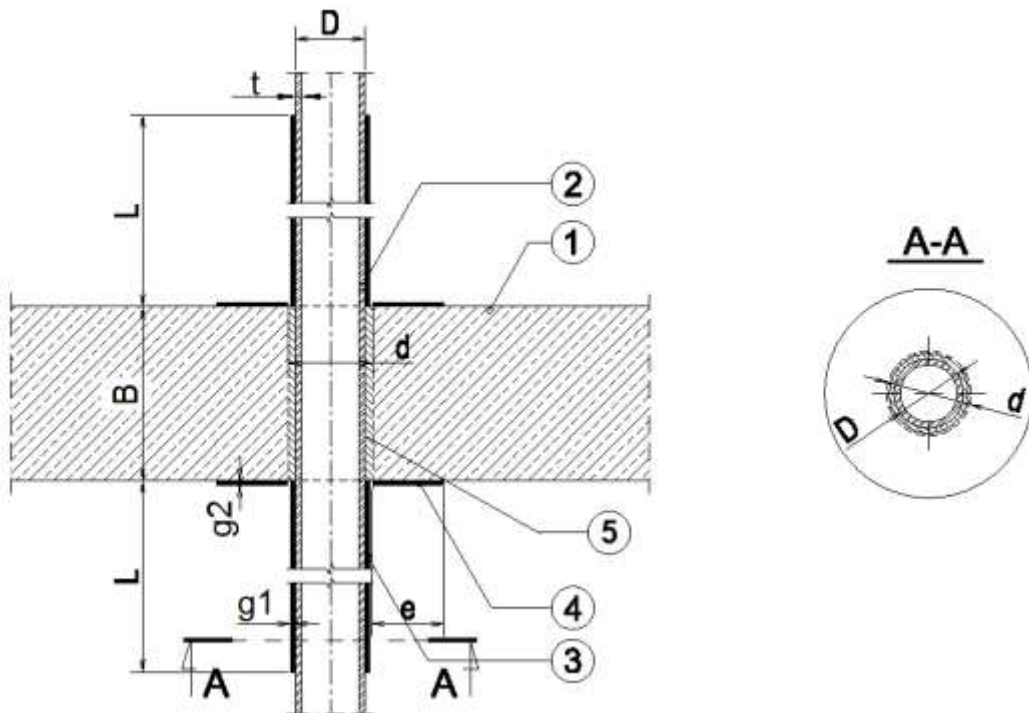

- 1 Floor supporting construction thickness of min. 150 mm;
- 2 Metal pipe, diameter of "D" and pipe wall thickness of "t"
- 3 PiroCoat I (pipe cover), thickness of $g_1 = \text{min. } 1,2 \text{ mm}$ and length of min. 500 mm
- 4 PiroCoat I (ring on the floor around the penetration seal), thickness of $g_2 = \text{min. } 0,6 \text{ mm}$; length of $e = \text{min. } 60 \text{ mm}$
- 5 Gap between the pipe and supporting construction filled with cement mortar, thickness of $u = \text{max. } 15 \text{ mm}$

PiroCoating, PiroCoat I and PiroCoat A

Construction details
Non-insulated metal pipes penetration seals in rigid floor

Annex C16
of European
Technical Assessment
ETA-17/1062

Fig. C17. Plastic pipes penetration seals in rigid floor (with continuous mineral wool insulation).

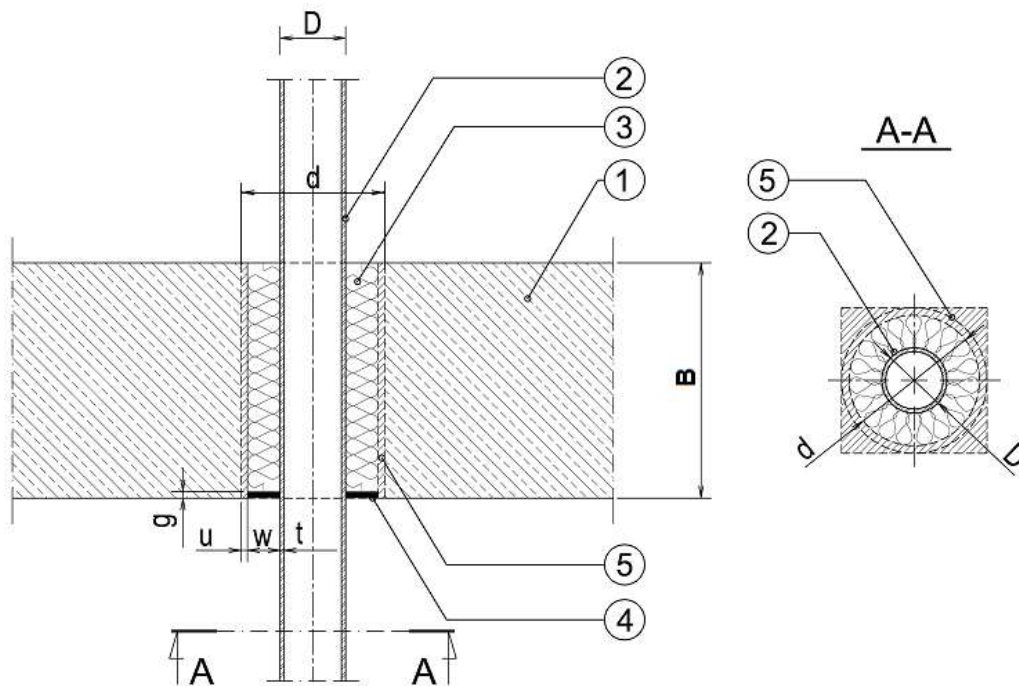

- 1 Floor supporting construction thickness of min. 150 mm
- 2 Plastic pipe diameter of "D" and pipe wall thickness of "t" in accordance with table C2
- 3 Mineral wool, density of 50 kg/m³, maximum width of w = 15 mm
- 4 PiroCoat I, thickness of min. 5 mm
- 5 Gap between the mineral wool and supporting construction filled with cement mortar, thickness of max. 17,5 mm

Table C2

Pipe material	Pipe diameter, D [mm]	Pipe wall thickness, t [mm]	Opening max. diameter, d [mm]	Min. thickness of mineral wool / min. length of PiroCoat I, w [mm]	Min. thickness of PiroCoat I, g [mm]
PE-HD	≤ 40	3,0	85	15	5
PP	≤ 40	1,9	85	15	5
PVC	≤ 40	2,0	85	15	5

PiroCoating, PiroCoat I and PiroCoat A

Construction details
Insulated plastic pipes penetration seals in rigid floor

Annex C17
of European
Technical Assessment
ETA-17/1062

Fig. C18. Small cables ($\varnothing \leq 21$ mm) penetration seals in rigid floor thickness of $t \geq 150$ mm, made with use of PiroCoating.

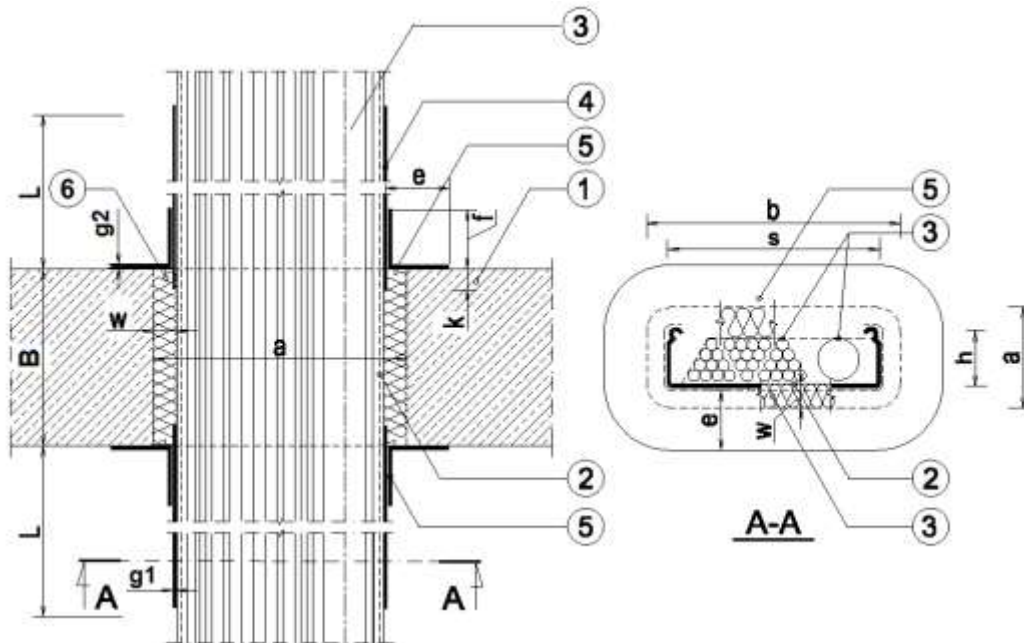

- 1 Floor supporting construction thickness of min. 150 mm
- 2 Cable tray
- 3 Cables diameter of max. 21 mm
- 4 PiroCoating; both sides of the floor, length of $L = \text{min. } 300$ mm, depth of $k = \text{min. } 30$ mm, thickness of $g2 = \text{min. } 1,2$ mm
- 5 PiroCoating, both sides of the floor, dimensions: $f = \text{min. } 50$ mm, $e = \text{min. } 50$ mm, $g1 = \text{min. } 0,6$ mm
- 6 Mineral wool, density of 50 kg/m^3 , thickness $w = \text{max. } 40$ mm

PiroCoating, PiroCoat I and PiroCoat A

Construction details
Cables penetration seals in rigid floor

Annex C18
of European
Technical Assessment
ETA-17/1062

Fig. C19. Plastic pipes penetration seals in rigid floor, made with use of PiroCoat A and Piro Multitube PM dimensions of (length x thickness)100 x 9,6 mm (with continuous mineral wool insulation).

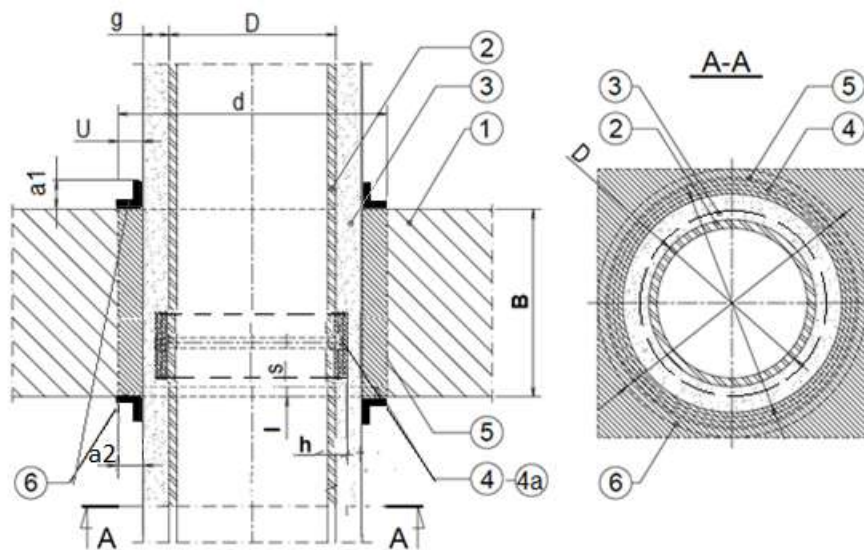

- 1 Rigid floor (of concrete or reinforced concrete) with minimum thickness of $B = 150$ mm
- 2 Plastic pipe diameter of "D" and pipe wall thickness "t"
- 3 Mineral wool density of min. 50 kg/m^3 (continuous insulation)
- 4 Piro Multitube PM dimensions of (length x thickness) $100 \times 9,6$ ($2 \times 4,8$) mm, placed inside the floor, in the distance of 15 ± 5 mm from the floor bottom
- 4a Self-adhesive tape
- 5 Space between the floor and the service filled with cement mortar, max. 25 mm
- 6 PiroCoat IPasta A on both sides of the floor; length $a1 = \text{min. } 50$ mm, thickness $g1 = \text{min. } 0,6$ mm, width $a2 = \text{min. } 50$ mm, thickness $g2 = \text{min. } 0,6$ mm

PiroCoating, PiroCoat I and PiroCoat A

Construction details
Insulated plastic pipes penetration seals in rigid floor

Annex C19
of European
Technical Assessment
ETA-17/1062

Fig. C20. Metal pipes penetration seals in rigid floor, made with use of PiroCoat A (with continuous mineral wool insulation).

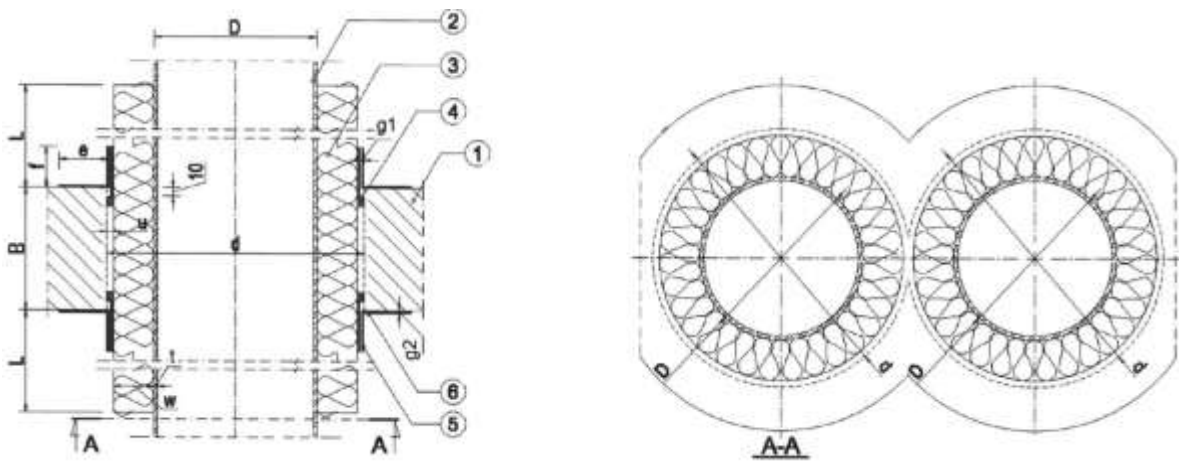

- 1 Rigid floor (of concrete or reinforced concrete) with minimum thickness of $B = 150$ mm
- 2 Metal pipe diameter of "D" and pipe wall thickness "t"
- 3 Mineral wool density of 50 kg/m^3 , thickness of 30 mm (continuous insulation)
- 4 Space between the floor and the service filled with cement mortar, max. 25 mm
- 5 PiroCoat IPasta A on both sides of the floor, length $f = 50$ mm, thickness $g1 = 0,6$ mm
- 6 PiroCoat IPasta A on both sides of the floor, width $e = 50$ mm, thickness $g2 = 0,6$ mm

PiroCoating, PiroCoat I and PiroCoat A

Construction details
Insulated metal pipes penetration seals in rigid floor

Annex C20
of European
Technical Assessment
ETA-17/1062

Fig. C21. Metal pipes bundles (max. 2 copper pipes in bundles, diameter of $D1 \leq 22,2$ mm and pipe wall thickness of $t1 \geq 1,2$ mm and/or max. 2 steel pipes in bundle, diameter of $D2 \leq 17,3$ mm and pipe wall thickness of $t2 \geq 1,8$ mm) penetration seals in rigid floor thickness of $t \geq 150$ mm, made with use of PiroCoat I.

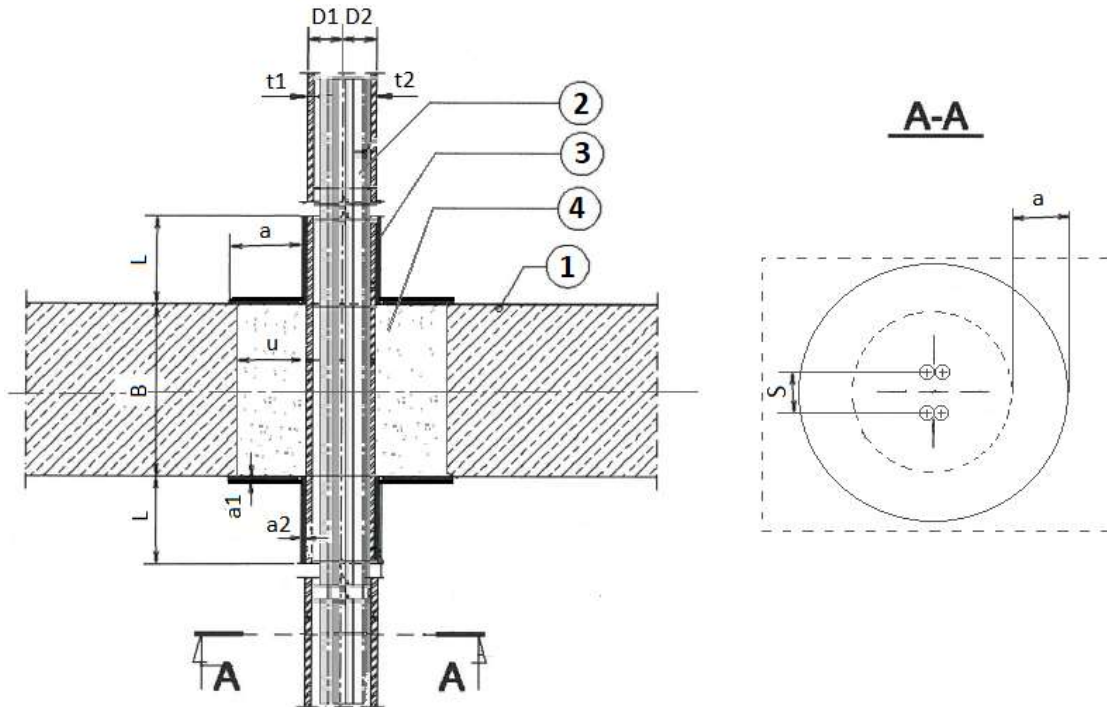

- 1 Rigid floor (of concrete or reinforced concrete) with minimum thickness of $B = 150$ mm
- 2 Bundle of metal pipe consisting of max. 2 copper pipes diameter of $D1 \leq 22,2$ mm and pipe wall thickness of $t1 \geq 1,2$ mm and/or max. 2 steel pipes diameter of $D2 \leq 17,3$ mm and pipe wall thickness of $t2 \geq 1,8$ mm; pipes in bundle placed in the min. distance of $s = 40$ mm
- 3 PiroCoat IPasta I (placed on each pipe) on the length $L = 500$ mm, thickness $a2 = 1,2$ mm, width $a = 50$ mm (around the pipes) and thickness $a1 = 0,6$ mm
- 4 Space between the floor and the service filled with cement mortar, max. 25 mm

PiroCoating, PiroCoat I and PiroCoat A

Construction details

Non-insulated metal pipes bundle penetration seals in rigid floor

Annex C21
of European
Technical Assessment
ETA-17/1062

Fig. C22. Plastic pipes bundles (max. 4 pipes in bundles, consisting of max. 2 x PP-R/PP-R+GF/PP-R pipes diameter of max. 20 mm and pipe wall thickness of 4,0 mm and 2 x PE-RT/AL/PE-RT pipes diameter of max. 50 mm and pipe wall thickness of 5,5 mm), with additional small cable ($\varnothing \leq 14$ mm) outside the bundle penetration seals in rigid floor thickness of $t \geq 150$ mm, made with use of PiroCoating and Piro Multitube PM dimensions of (length x thickness) 9,6 x 100 mm.

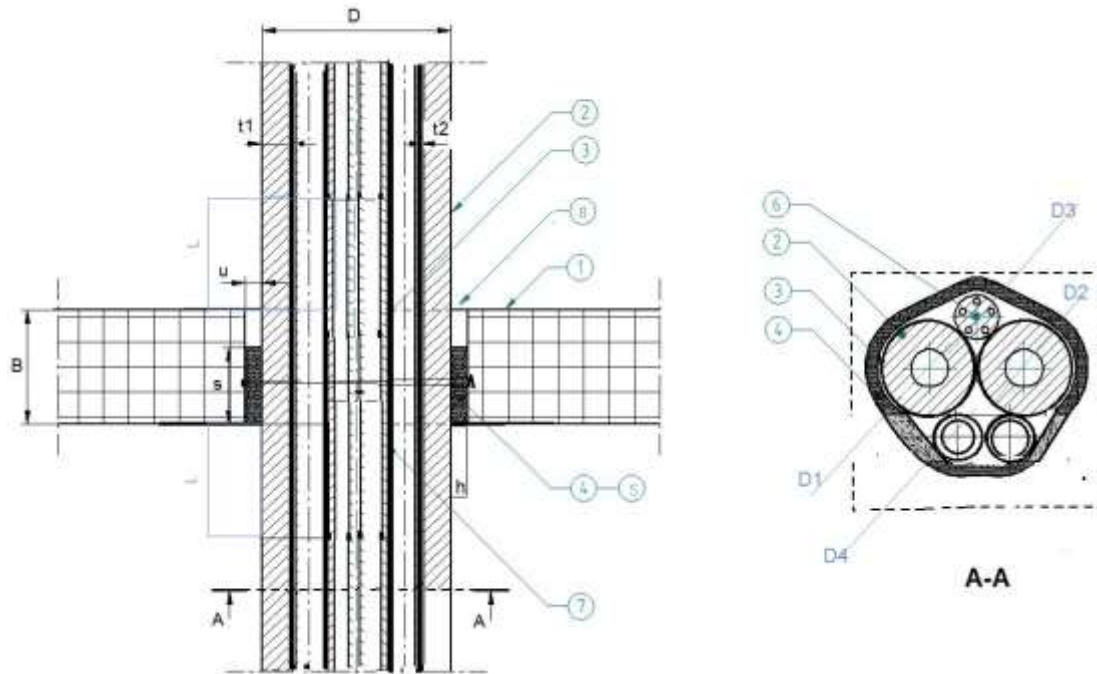

- 1 Rigid floor (of concrete or reinforced concrete) with minimum thickness of $B = 150$ mm
- 2 Two plastic pipes made of PE-RT/AL/PE-RT diameter of $D1/D2 \leq 50$ mm and pipe wall thickness of $t1, t2 = 5,5$ mm
- 3 Two plastic pipes made of PP-R/PP-R+GF/PP-R diameter of $D4 \leq 20$ mm and pipe wall thickness of $t3 = 4,0$ mm
- 4 Piro Multitube PM dimensions of (length x thickness) $100 \times 9,6$ ($2 \times 4,8$) mm, placed inside the floor, in the distance of 15 ± 5 mm from the floor bottom
- 5 Self-adhesive tape
- 6 Small cable covered with PiroCoating on the length $L = \text{min. } 300$ mm and thickness $g1 = \text{min. } 1,2$ mm
- 7 PiroCoating on the length $L = \text{min. } 300$ mm and thickness $g1 = \text{min. } 1,2$ mm
- 8 Space between the floor and the service filled with cement mortar, max. 25 mm

PiroCoating, PiroCoat I and PiroCoat A

Construction details

Non-insulated plastic pipes bundle penetration seals in rigid floor

Annex C22
of European
Technical Assessment
ETA-17/1062

Fig. C23. Single or double copper pipe with PE foam insulation with additional small cable ($\varnothing \leq 14$ mm) outside the bundle in rigid floor, made with use of PiroCoating, PiroCoat I and Piro Multitube PM dimensions of (thickness x length) 4,0 x 60 mm.

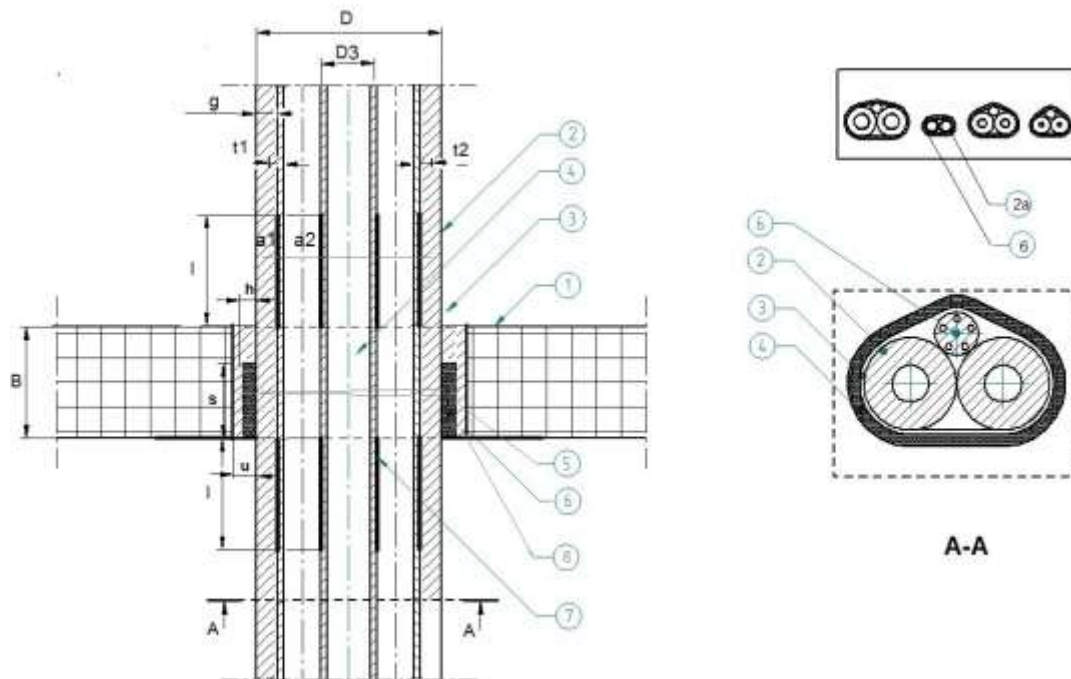

- 1 Rigid floor (of concrete or reinforced concrete) with minimum thickness of $B = 150$ mm
- 2 Metal pipes diameter of $D1, D2$ and pipe wall thickness of $t1, t2$
- 3 Tubolit insulation made of PE on the metal pipes, thickness of g (continuous insulation)
- 4 Small cable, diameter of $D3$ covered with PiroCoating on the length of $L = \text{min. } 300$ mm, thickness of $a1 = \text{min. } 1,2$ mm
- 5 Self-adhesive tape
- 6 Piro Multitube PM dimensions of (length x thickness) $60 \times 4,0$ mm, placed inside the floor, in the distance of 15 ± 5 mm from the floor bottom
- 7 PiroCoat IPasta I on the metal pipes with PE insulation, length of the $L = \text{min. } 300$ mm thickness of $g1 = \text{min. } 1,2$ mm
- 8 Space between the floor and the service filled with cement mortar, max. 25 mm

PiroCoating, PiroCoat I and PiroCoat A

Construction details
Non-insulated metal pipes penetration seals in rigid floor

Annex C23
of European
Technical Assessment
ETA-17/1062

Fig. C24. Steel pipes type Geberit N in rigid floor, made with use of PiroCoat I and PiroCoat A Pasta (without insulation).

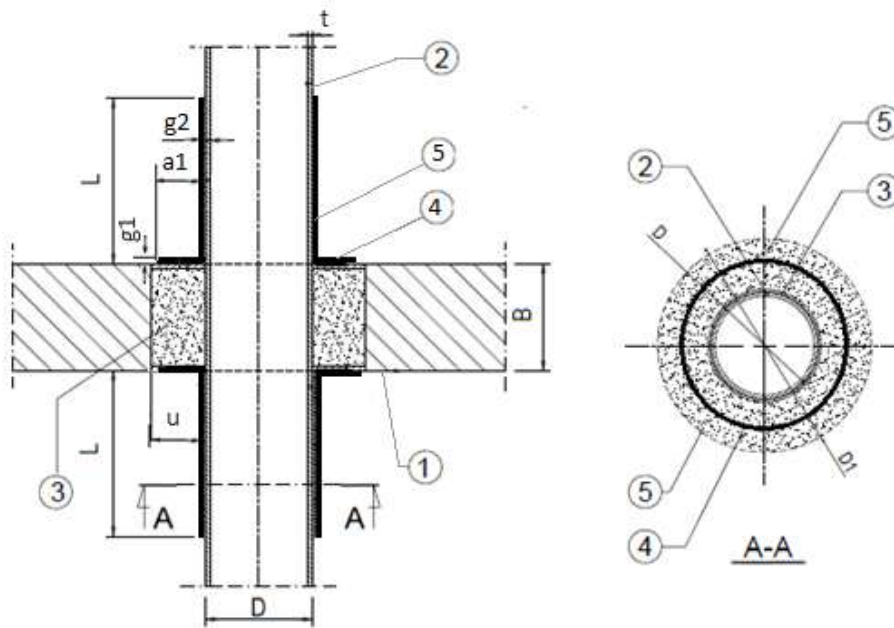

- 1 Rigid floor (of concrete or reinforced concrete) with minimum thickness of $B = 150$ mm
- 2 Metal pipe, diameter of D and pipe wall thickness of t
- 3 Space between the floor and the service filled with cement mortar, $u = \max. 10$ mm
- 4 PiroCoat IPasta I; length $L = 500$ mm, thickness of $g2 = 1,2$ mm
- 5 PiroCoat IPasta A width $a1 = 50$ mm, thickness of $g1 = 0,6$ mm

PiroCoating, PiroCoat I and PiroCoat A

Construction details
Non-insulated metal pipes penetration seals in rigid floor

Annex C24
of European
Technical Assessment
ETA-17/1062

Fig. C25. Construction details of mixed penetration seal

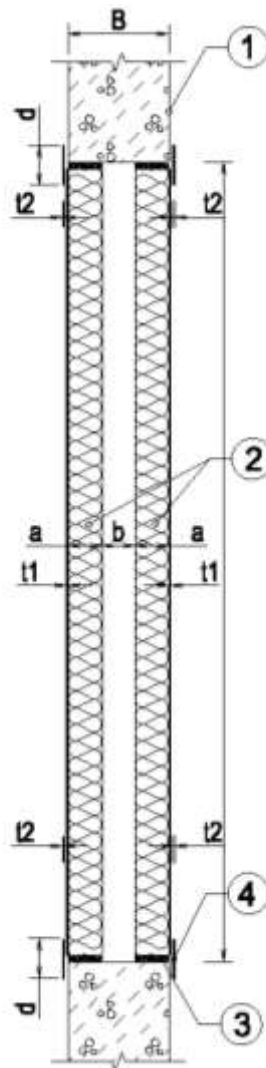

- 1 Rigid wall with a minimum density of 600 kg/m³ and thickness of $B \geq 150$ mm or rigid floor with a minimum density of 1700 kg/m³ and thickness of $B \geq 150$ mm
- 2 2 mineral wool boards with a minimum density of 150 kg/m³, thickness of $a \geq 50$ mm, covered with PiroCoat A with thickness of $t1 \geq 1,2$ mm; $b \geq 50$ mm (space between the boards)
- 3 PiroCoat A; length ≥ 50 mm, thickness $\leq 5,0$ mm
- 4 PiroCoat A on both sides of the wall or floor (placed on the perimeter of the mixed penetration seal); length $d \geq 60$ mm, thickness $t2 \geq 0,6$ mm

PiroCoating, PiroCoat I and PiroCoat A

Construction details
Mixed penetration seals

Annex C25
of European
Technical Assessment
ETA-17/1062

Fig. C26. Cables in cable tray mixed penetration seal in rigid wall, made with use of PiroCoating

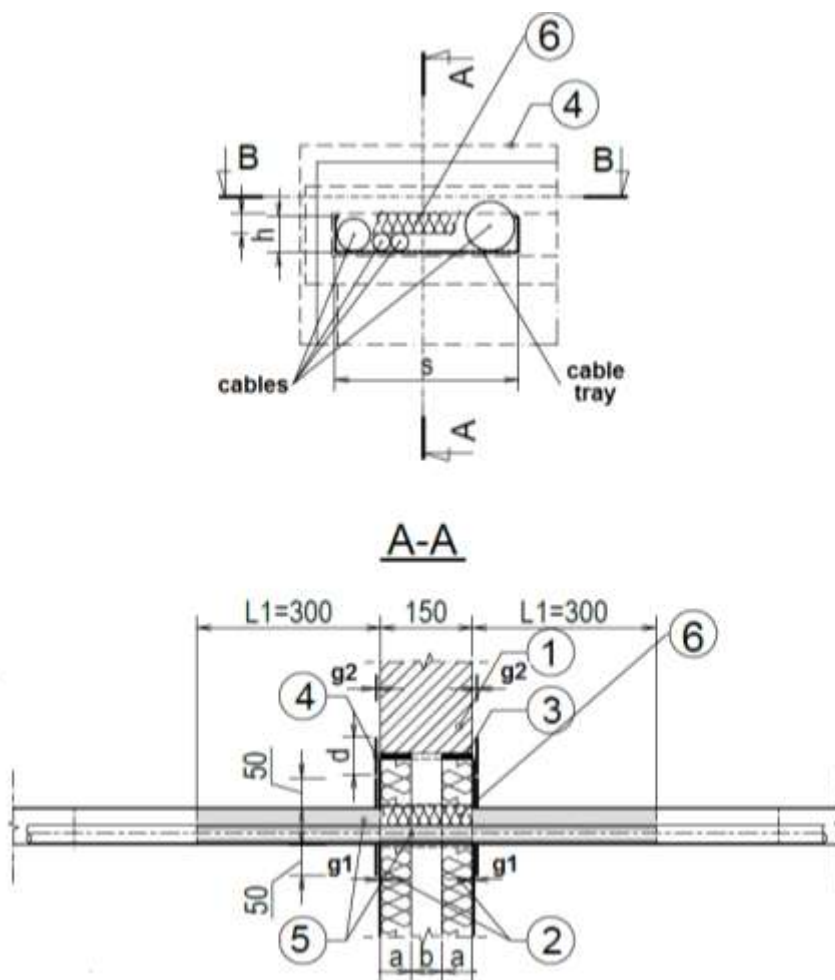

- 1 Rigid wall with a minimum density of $\geq 600 \text{ kg/m}^3$ and minimum thickness of 150 mm
- 2 two mineral wool boards with a minimum density of 150 kg/m^3 , thickness of $a \geq 50 \text{ mm}$, covered with PiroCoat A, thickness of $g1 \geq 1,2 \text{ mm}$; $b \geq 50 \text{ mm}$ (space between the boards)
- 3 PiroCoat A; length $\geq 50 \text{ mm}$, thickness $\leq 5,0 \text{ mm}$
- 4 PiroCoat A on both sides of the wall (placed on the perimeter of the mixed penetration seal); length $d \geq 60 \text{ mm}$, thickness $g2 \geq 0,6 \text{ mm}$
- 5 PiroCoating on both sides of the penetration seal, on cables and cable trays (with dimensions of $h \times s$); coating length of $L1 \geq 300 \text{ mm}$ and thickness $\geq 1,2 \text{ mm}$
- 6 Empty space in the cable tray filled with mineral wool with a minimum density of 40 kg/m^3

PiroCoating, PiroCoat I and PiroCoat A

Construction details
Cables in cable tray mixed penetration seals in rigid wall

Annex C26
of European
Technical Assessment
ETA-17/1062

Fig. C27. Cables in cable tray mixed penetration seal in rigid floor, made with use of PiroCoating

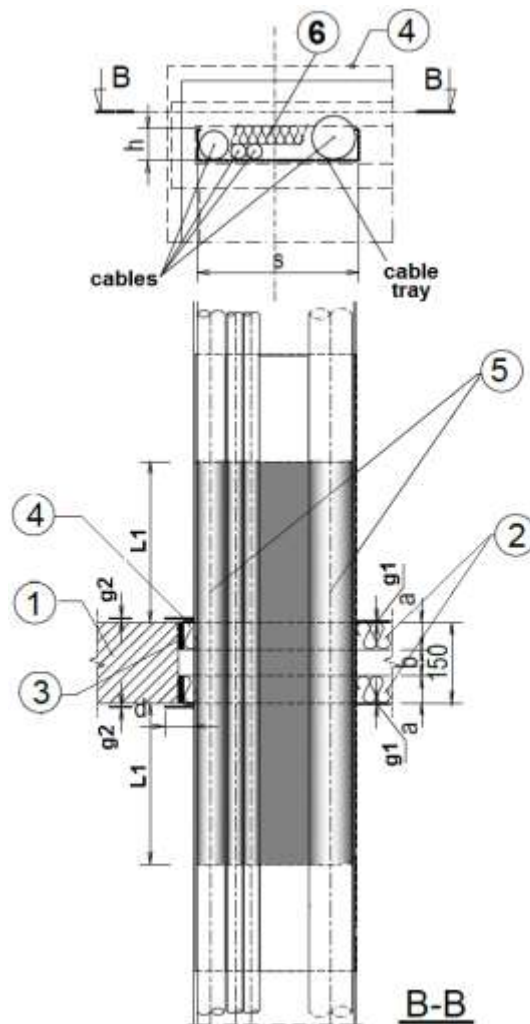

- 1 Rigid floor with a minimum density of 1700 kg/m³ and minimum thickness of 150 mm
- 2 Two mineral wool boards with a minimum density of 150 kg/m³, thickness of $a \geq 50$ mm, covered with PiroCoat A, thickness of $g_1 \geq 1,2$ mm; $b \geq 50$ mm (space between the boards)
- 3 PiroCoat A; length ≥ 50 mm, thickness $\leq 5,0$ mm
- 4 PiroCoat A on both sides of the floor (placed on the perimeter of the mixed penetration seal); length $d \geq 60$ mm, thickness $g_2 \geq 0,6$ mm
- 5 PiroCoating on both sides of the penetration seal, on cables and cable trays (with dimensions of $h \times s$); coating length of $L_1 \geq 300$ mm and thickness $\geq 1,2$ mm
- 6 Empty space in the cable tray filled with mineral wool with a minimum density of 40 kg/m³

PiroCoating, PiroCoat I and PiroCoat A

Construction details
Cables in tray mixed penetration seals in rigid wall

Annex C27
of European
Technical Assessment
ETA-17/1062

Fig. C28. Plastic pipe mixed penetration seal in rigid wall, made with use of PiroCoat A and Piro Collar PC

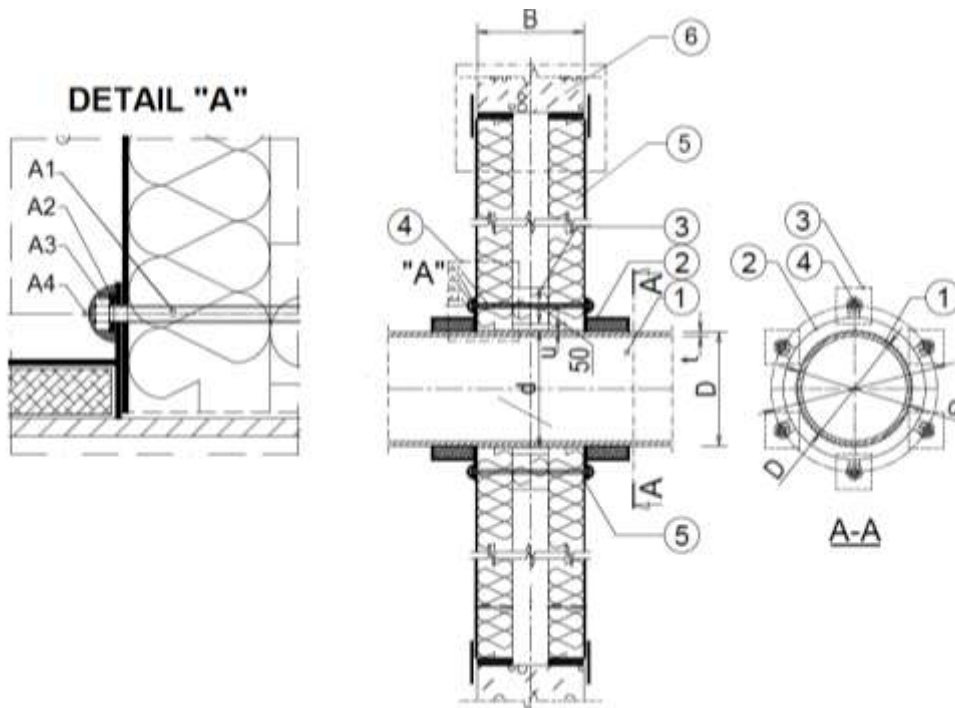

- 1 Plastic pipe in accordance with table C3; distance of $u \leq 10$ mm
- 2 Piro Collar PC, fixed on both sides of the wall, outside of the penetration seal, number of fixing points in accordance with table C3
- 3 Mineral wool with a minimum density of 150 kg/m^3 ; minimum dimensions of $50 \times 50 \times 50$ mm
- 4 Steel threaded rod M6 (A1), pad, 2 pcs. (A2), steel nut (A3), PiroCoat A (A4)
- 5 Construction of mixed penetration seal in accordance with fig. C25
- 6 Rigid wall with a minimum density of 600 kg/m^3 and thickness of $B \geq 150$ mm

Table C3

Pipe material	Fire resistance class	Pipe diameter, D [mm]	Pipe wall thickness, t [mm]	Intumescent material of Piro Collar PC		Number of fixing dowels
				thickness [mm]	width [mm]	
PE-HD	according to table B29	≤ 40	2,4	2,5	60	2
PE-HD		≤ 160	6,0	17	60	6
PP		≤ 40	2,0	2,5	60	2
PP		≤ 135	5,5	9,5	60	4
PVC		≤ 40	1,9	2,5	60	2
PVC		≤ 160	7,0	17	60	6

PiroCoating, PiroCoat I and PiroCoat A

Construction details
Insulated plastic pipes mixed penetration seals in rigid wall

Annex C28
of European
Technical Assessment
ETA-17/1062

Fig. C29. Plastic pipe mixed penetration seal in rigid floor, made with use of PiroCoat A and Piro Collar PC

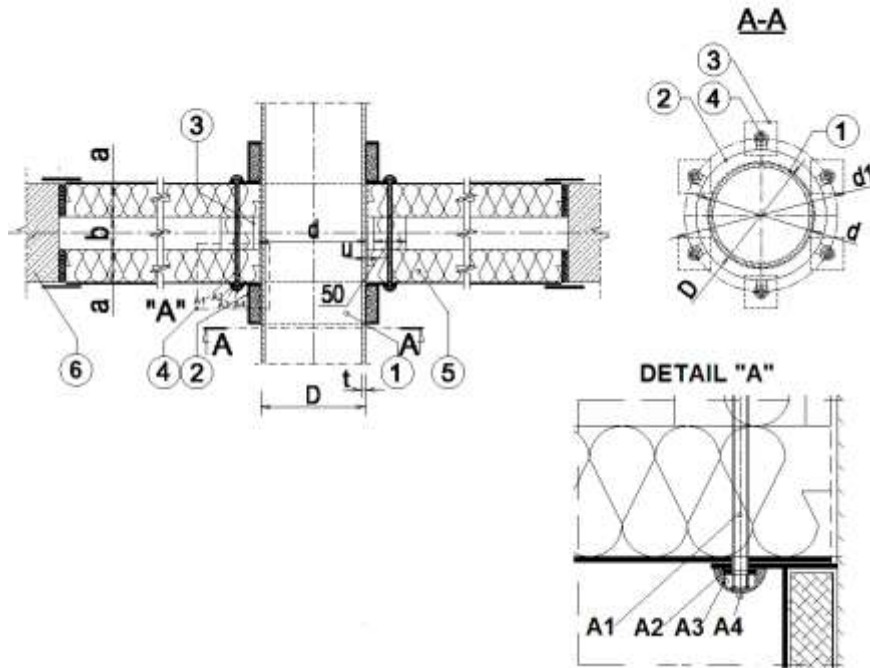

- 1 Plastic pipe in accordance with table C4; distance of $u \leq 10$ mm
- 2 Piro Collar PC, fixed on the bottom of the floor, outside of the penetration seal, number of fixing points in accordance with table C4
- 3 Mineral wool with a minimum density of 150 kg/m^3 ; minimum dimensions of $50 \times 50 \times 50$ mm
- 4 Steel threaded rod M6 (A1), pad, 2 pcs. (A2), steel nut (A3), PiroCoat A (A4)
- 5 Construction of mixed penetration seal in accordance with fig. C25
- 6 Rigid floor with a minimum density of 1700 kg/m^3 and thickness of $B \geq 150$ mm

Table C4

Pipe material	Fire resistance class	Pipe diameter, D [mm]	Pipe wall thickness, t [mm]	Intumescent material of Piro Collar PC		Number of fixing dowels
				thickness [mm]	width [mm]	
PE-HD	according to table B30	≤ 40	2,4	2,5	60	2
PE-HD		≤ 160	6,0	17	60	6
PP		≤ 40	2,0	2,5	60	2
PP		≤ 135	5,5	9,5	60	4
PVC		≤ 40	1,9	2,5	60	2
PVC		≤ 160	7,0	7,0	17	60

PiroCoating, PiroCoat I and PiroCoat A

Construction details
Insulated plastic pipes mixed penetration seals in rigid floor

Annex C29
of European
Technical Assessment
ETA-17/1062

Fig. C30. Metal pipe mixed penetration seal in rigid wall, made with use of PiroCoat A and Piro Collar PC (with synthetic flexible elastomeric foam insulation FEF)

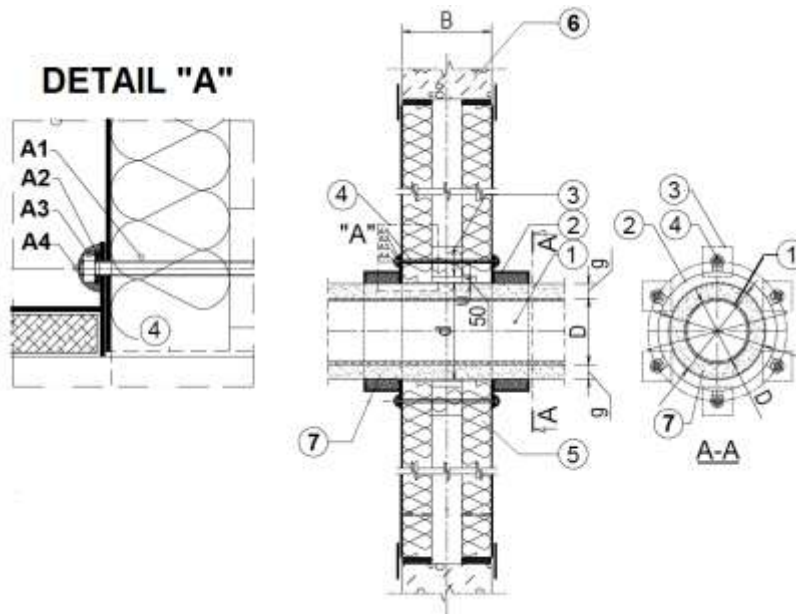

- 1 Metal pipe in accordance with table C5; distance of $u \leq 15$ mm
- 2 Piro Collar PC, fixed on both sides of the wall, outside of the penetration seal, number of fixing points in accordance with table C5
- 3 Mineral wool with a minimum density of 150 kg/m^3 ; minimum dimensions of $50 \times 50 \times 50$ mm
- 4 Steel threaded rod M6 (A1), pad, 2 pcs. (A2), steel nut (A3), PiroCoat A (A4)
- 5 Construction of mixed penetration seal in accordance with fig. C25
- 6 Rigid wall with a minimum density of 600 kg/m^3 and thickness of $B \geq 150$ mm
- 7 Flexible elastomeric foam (FEF) insulation, thickness in accordance with table C5

Table C5

Pipe material	Fire resistance class	Pipe diameter, D [mm]	Pipe wall thickness, t [mm]	Intumescent material of Piro Collar PC		Number of fixing dowels
				thickness [mm]	width [mm]	
PE-HD	according to table B31	≤ 40	2.4	2.5	60	2
PE-HD		≤ 160	6.0	17	60	6
PP		≤ 40	2.0	2.5	60	2
PP		≤ 135	5.5	9.5	60	4
PVC		≤ 40	1.9	2.5	60	2
PVC		≤ 160	7.0	17	60	6

PiroCoating, PiroCoat I and PiroCoat A

Construction details
Insulated metal pipes mixed penetration seals in rigid wall

Annex C30
of European
Technical Assessment
ETA-17/1062

Fig. C31. Metal pipe mixed penetration seal in rigid floor, made with use of PiroCoat A and Piro Collar PC (with synthetic flexible elastomeric foam insulation FEF)

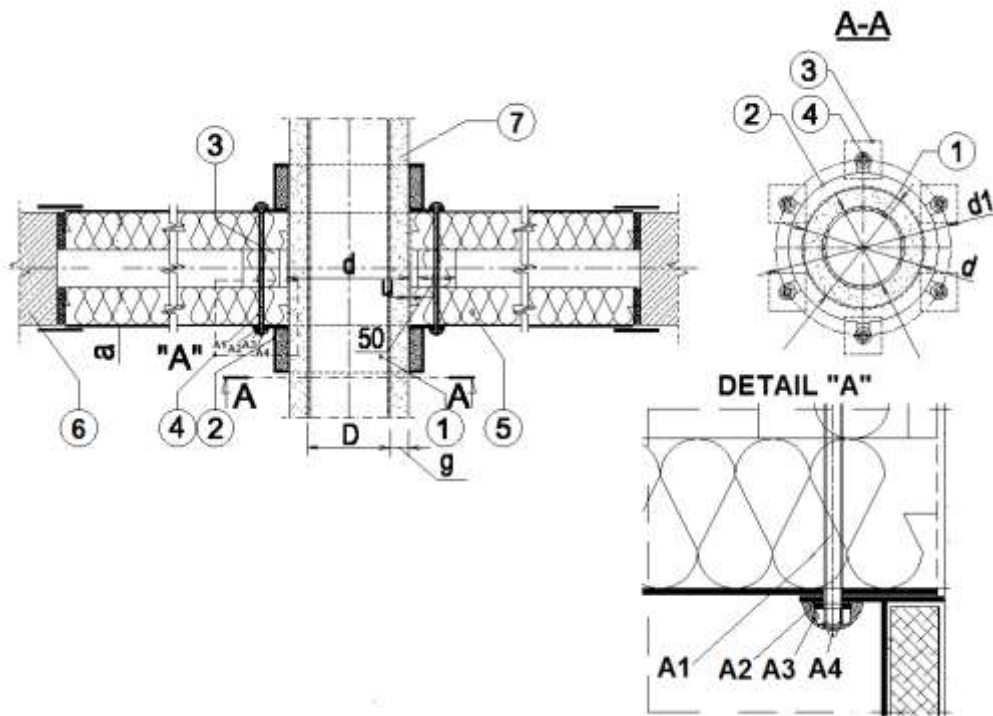

- 1 Metal pipe in accordance with table C6; distance of $u \leq 15$ mm
- 2 Piro Collar PC, fixed on both sides of the wall, outside of the penetration seal, number of fixing points in accordance with table C6
- 3 Mineral wool with a minimum density of 150 kg/m^3 ; minimum dimensions of $50 \times 50 \times 50$ mm
- 4 Steel threaded rod M6 (A1), pad, 2 pcs. (A2), steel nut (A3), PiroCoat A (A4)
- 5 Construction of mixed penetration seal in accordance with fig. C25
- 6 Rigid floor with a minimum density of 1700 kg/m^3 and thickness of $B \geq 150$ mm
- 7 Flexible elastomeric foam (FEF) insulation, thickness in accordance with table C6

Table C6

Pipe material	Fire resistance class	Pipe diameter, D [mm]	Pipe wall thickness, t [mm]	Flexible elastomeric foam (FEF) insulation thickness, g [mm]	Intumescent material of Piro Collar PC		Number of fixing dowels
					thickness [mm]	width [mm]	
Steel	according to table B32	$\leq 17,2$	$\geq 2,0$	32	2,5	60	2
Steel		$\leq 17,2$	$\geq 4,0$	25	17,0	60	2
Steel		≤ 108	$4,0 - 14,2$	25	17,0	60	6

PiroCoating, PiroCoat I and PiroCoat A

Construction details
Insulated metal pipes mixed penetration seals in rigid floor

Annex C31
of European
Technical Assessment
ETA-17/1062

Fig. C32. Metal pipe mixed penetration seal in rigid wall, made with use of PiroCoat A (with mineral wool insulation)

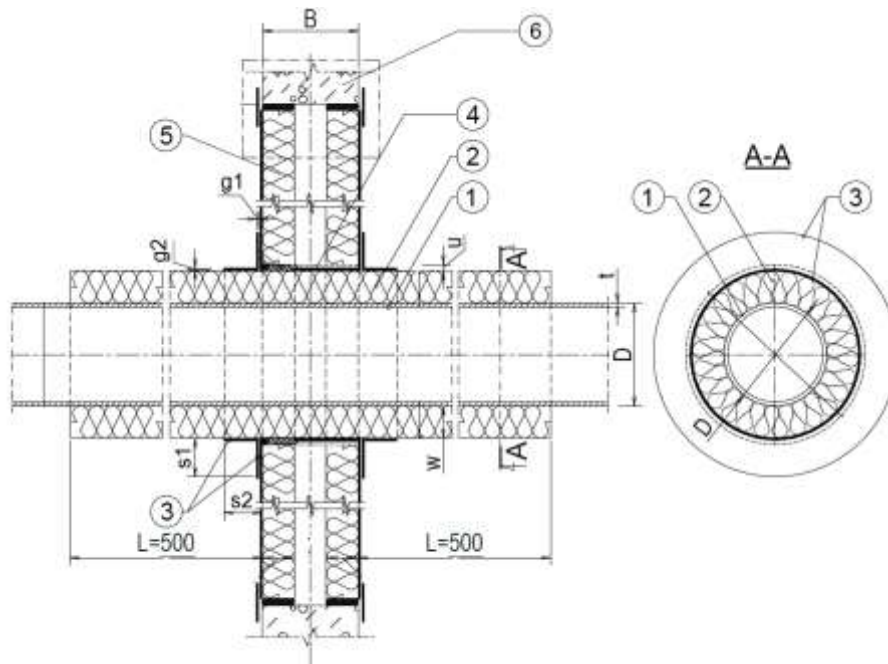

- 1 Metal pipe diameter of "D", pipe wall thickness "t"
- 2 Mineral wool with a minimum density of 40 kg/m³; length of L ≥ 500 mm, thickness of w ≥ 50 mm
- 3 PiroCoat A; length of s₁ ≥ 60 mm, thickness of g₁ ≥ 0,6 mm, length of s₂ ≥ 60 mm, thickness of g₂ ≥ 0,6 mm
- 4 Space between the pipe insulation and mixed penetration seal filled with PiroCoat A thickness of u ≤ 5 mm
- 5 Construction of mixed penetration seal in accordance with fig. C25
- 6 Rigid wall with a minimum density of 600 kg/m³ and thickness of B ≥ 150 mm

PiroCoating, PiroCoat I and PiroCoat A

Construction details

Insulated metal pipes mixed penetration seals in rigid wall

Annex C32
of European
Technical Assessment
ETA-17/1062

Fig. C33. Metal pipe mixed penetration seal in rigid floor, made with use of PiroCoat A (with mineral wool insulation)

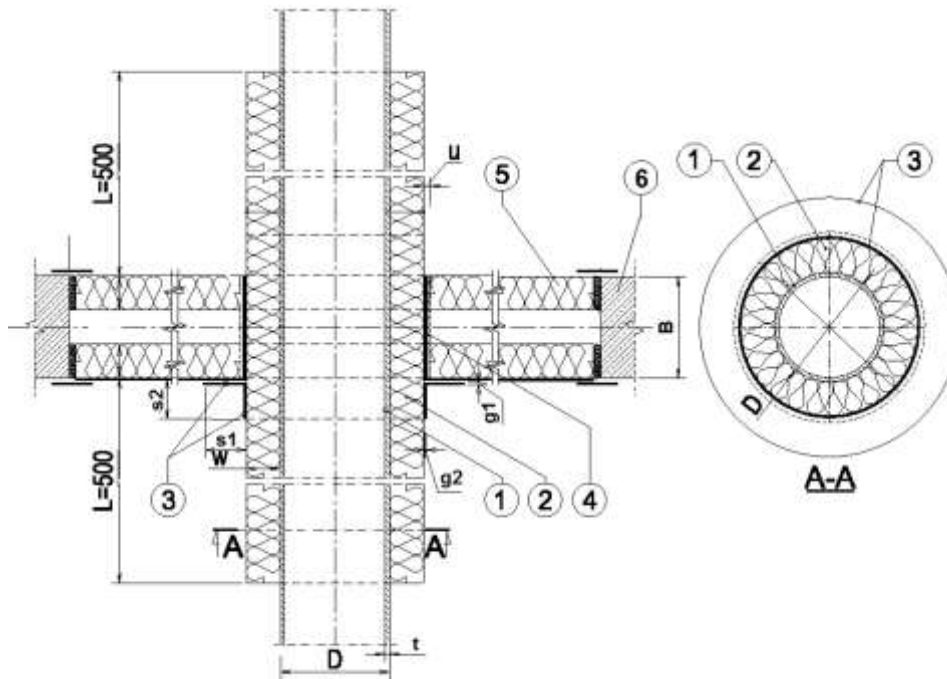

- 1 Metal pipe diameter of D, pipe wall thickness t
- 2 Mineral wool with a minimum density of 50 kg/m³; length of L ≥ 500 mm, thickness of w ≥ 50 mm
- 3 PiroCoat A; length of s1 ≥ 60 mm, thickness of g1 ≥ 0,6 mm, length of s2 ≥ 60 mm, thickness of g2 ≥ 0,6 mm
- 4 Space between the pipe insulation and mixed penetration seal filled with PiroCoat A thickness of u ≤ 5 mm
- 5 Construction of mixed penetration seal in accordance with fig. C25
- 6 Rigid floor with a minimum density of 1700 kg/m³ and thickness of B ≥ 150 mm

PiroCoating, PiroCoat I and PiroCoat A

Construction details
Insulated metal pipes mixed penetration seals in rigid floor

Annex C33
of European
Technical Assessment
ETA-17/1062

Fig. C34. Metal pipe mixed penetration seals in rigid floor, made with use of PiroCoat I (without insulation)

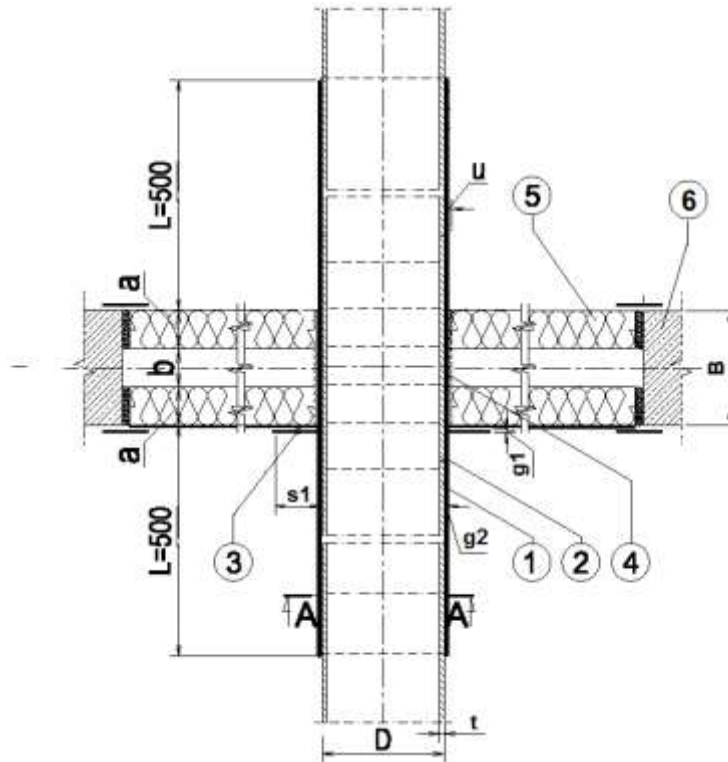

- 1 Steel pipe with diameter of $D \leq 273$ mm and pipe wall thickness of t from 6,0 to 14,2 mm
- 2 PiroCoat I, length of $L \geq 500$ mm, thickness of $g2 \geq 1,2$ mm
- 3 PiroCoat I, length of $s1 \geq 50$ mm, thickness of $g1 \geq 0,6$ mm
- 4 Space between the pipe and mixed penetration seal filled with PiroCoat I; thickness of $u \leq 5$ mm
- 5 Construction of mixed penetration seal in accordance with fig. C25
- 6 Rigid floor with a minimum density of 1700 kg/m^3 and thickness of $B \geq 150$ mm

PiroCoating, PiroCoat I and PiroCoat A

Construction details

Non-insulated metal pipes mixed penetration seals in rigid floor

Annex C34
of European
Technical Assessment
ETA-17/1062