

**OPERATION
AND MAINTENANCE MANUAL**

**Fire protection shut-off valve
mcr ZIPP**



Version 16.03.08.2

CONTENTS:

1. INTRODUCTION 3

2. THE SUBJECT OF THE MANUAL 3

3. DEVICE INTENDED USE..... 3

4. DEVICE DESIGN AND PRINCIPLE OF OPERATION..... 4

5. DEVICE LABELLING 5

6. DEVICE INSTALLATION..... 6

 6.1. INSPECTION BEFORE THE INSTALLATION 6

 6.2. FIXING HOLE..... 7

 6.3. EMBEDDING..... 7

 6.4. ELECTRICAL CONNECTIONS 10

7. TRANSPORT AND STORAGE CONDITIONS..... 11

8. MAINTENANCE AND SERVICE 11

9. WARRANTY CONDITIONS..... 11

Labelling used in the operation and maintenance manual

- Option available
- Option unavailable

NOTE

With the date of publication of the operation and maintenance manual, the previous versions are no longer valid.

The operation and maintenance manual does not concern the dampers manufactured before the date of its publication.

1. INTRODUCTION

The purpose of this operation and maintenance manual is to get the user acquainted with the intended use, design, the principle of operation, correct installation and operation of the product.

The manual also includes additional information about the operating conditions, maintenance and warranty conditions of the product.

2. THE SUBJECT OF THE MANUAL

This operation and maintenance manual concerns the entire group of fire protection shut-off valves of type ZIPP. Observing recommendations included in the manual ensures correct function of the device in terms of fire protection of rooms as well as safety of the system users.

3. DEVICE INTENDED USE

Application

A mcr ZIPP type valve may be used as a fire protection shut-off valve with a duct connection as well as a transfer valve (installation without ventilation ducts).

The valve may not work in systems exposed to dust, except for when they are included in a special, individually developed programme of service and technical inspections.

Fire resistance

The mcr ZIPP type fire protection shut-off valve has the following fire resistance:

- EI120S for duct installation in walls and ceilings
- EI120 for installation without ducts in ceilings

Performance versions

The mcr ZIPP valve can be used as:

- a valve with a thermal release – variant:
 - RST – (automatic release)
- valve with an electromagnetic release – variant:
 - EK I - (remote release by operation of a "current pulse" – applying supply voltage)
 - EK P - (remote release by operation of a "current gap" – removing supply voltage)

The thermal release always has a principal role and ensures that the safe position of a valve is reached (activated) regardless of the operation of the electromagnetic release.

Optionally, there is a possibility to provide the valve with WK1 limit switches that signal the valve operation status (open/closed) and an intermediate module MP230/24 that allows the release of the device using the 230V AC voltage.

NOTE

As a default, the valve release temperature equals 72°C. In case another temperature value from the scope 57-100°C, it has to be specified in the order.

Dimension range

The mcr ZIPP type valve is manufactured in the following dimensions - diameters:

- Ø100
- Ø125
- Ø160
- Ø200

4. DEVICE DESIGN AND PRINCIPLE OF OPERATION

Design

The basic valve components include: a body with a round cross-section, a mobile shut-off cover (a mushroom), a connection stub pipe and a release and control mechanism started automatically after the thermal release or an electromagnetic release. The connection stub pipe is made of galvanised steel sheet. The valve nozzle is made of powder-painted steel sheet. The isolation partition is made of a fire resistant material, covered from outside with powder-painted steel sheet. The partition is set on a partially threaded mobile pin guided through the mechanism body.

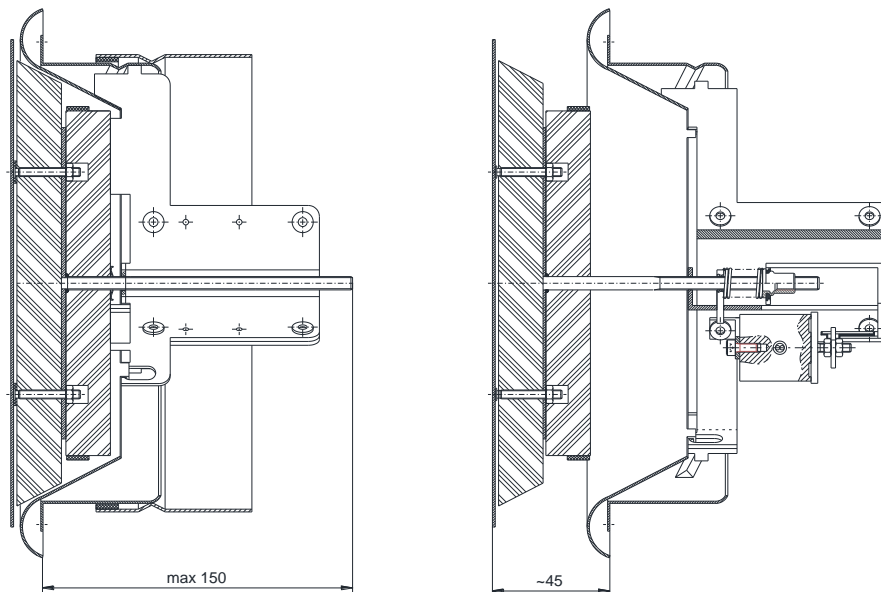

Action

In a normal position, the shut-off valve is open. Closing the valve (safety position) takes place:

- remotely, by activation of an electromagnetic release 24V DC (controlling by the "current impulse" or a "current gap"),
- automatically, by activation of the thermal release

The design of the drive system allows regulation of performance during the time of normal valve operation (setting the gap between the mechanism body and the mushroom). The regulation takes place by rotating the mushroom along the valve axis. The flow is increased by rotating the mushroom in the counter-clockwise direction and decreased by rotating it in the clockwise direction.

NOTE

Under any circumstances do not tug at the valve cover shield in order to open it.

Release and control mechanisms

A release and control mechanism for the mcr ZIPP valve can be:

- An RST type mechanism composed of a drive spring and a fuse release
- An RST+EKI24 type mechanism composed of a drive spring, a fuse release and an electromagnetic release started by applying the supply voltage.
- An RST+EKP24 type mechanism composed of a drive spring, a fuse release and an electromagnetic release started by removing the supply voltage.

Optionally, there is a possibility to equip the valve with WK1 limit switches that signal the valve operation status (open/closed) and an intermediate module MP230/24 that allows the release of the device using the 230V AC voltage.

Main dimensions

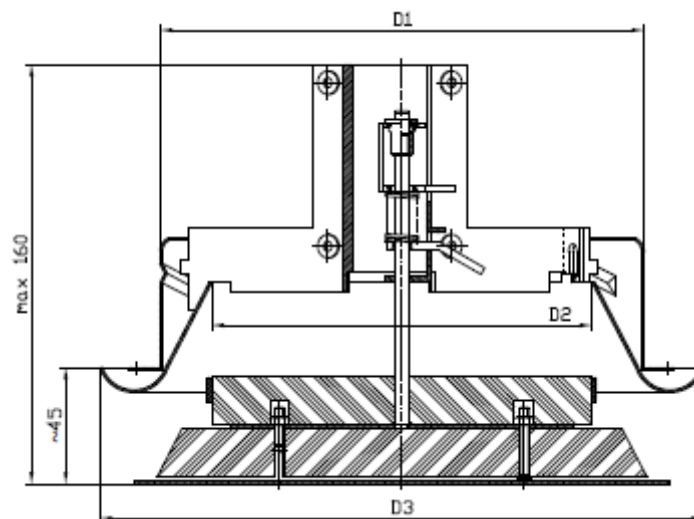

DIA	D1	D2	D3
[mm]			
100	98	73	139
125	123	96	164
160	158	128	207
200	198	156	254

Main dimensions of the mcr ZIPP fire protection shut-off valve

5. DEVICE LABELLING

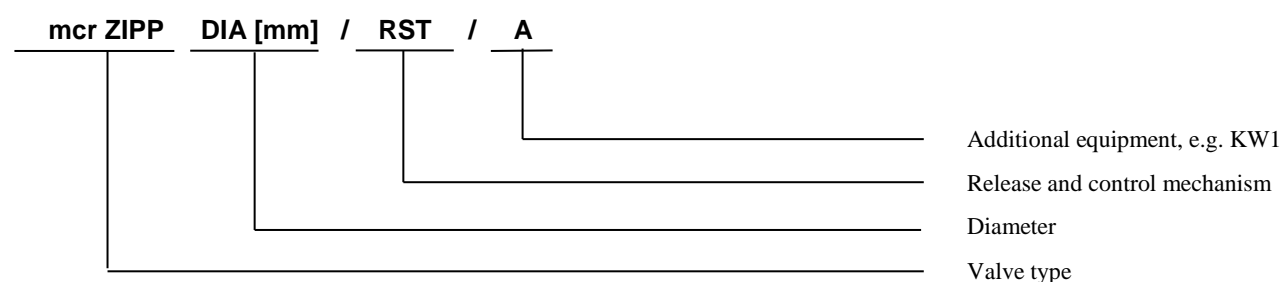

NOTE

As a default, the valve release temperature equals 72°C. In case another temperature value from the scope 57-100°C, it has to be specified in the order.

6. DEVICE INSTALLATION

NOTE

During the installation of valve and the finishing works, take into account the possibility of access to the device later and the disassembly of release and control mechanism in order to carry out the possible service works and technical inspections.

The mcr ZIPP valve can be installed in the following partitions (walls or ceilings):

- masonry walls – concrete with a thickness of at least 110 mm
- masonry walls from bricks or blocks at least 120 mm thick
- walls from panels at least 125 mm thick
- ceilings of at least 150 mm

Additionally, the valve can be installed:

- outside walls
- in batteries (multiple sets)

The mcr ZIPP shut-off valve may also be installed in partitions with lower fire resistance class. In case of such an installation, valves have fire protection equal to the fire protection of the partition, maintaining the smoke tightness criteria.

6.1. INSPECTION BEFORE THE INSTALLATION

Each valve is inspected before packaging and transporting by the manufacturer. After unpacking at the recipient, inspect visually in terms of possible deformation of the casing or damper damage during transport.

The valve is delivered in the closed position. Before installation, it should be armed.

In order to arm the RST mechanism, the following actions have to be taken:

- screw the valve from the connection stub pipe
- rotate the valve so that the mushroom is on top
- simultaneously release the locking sheet and press the valve nozzle at its circumference (fig. 4a)
- push the fuse element onto the catches (fig. 4b)

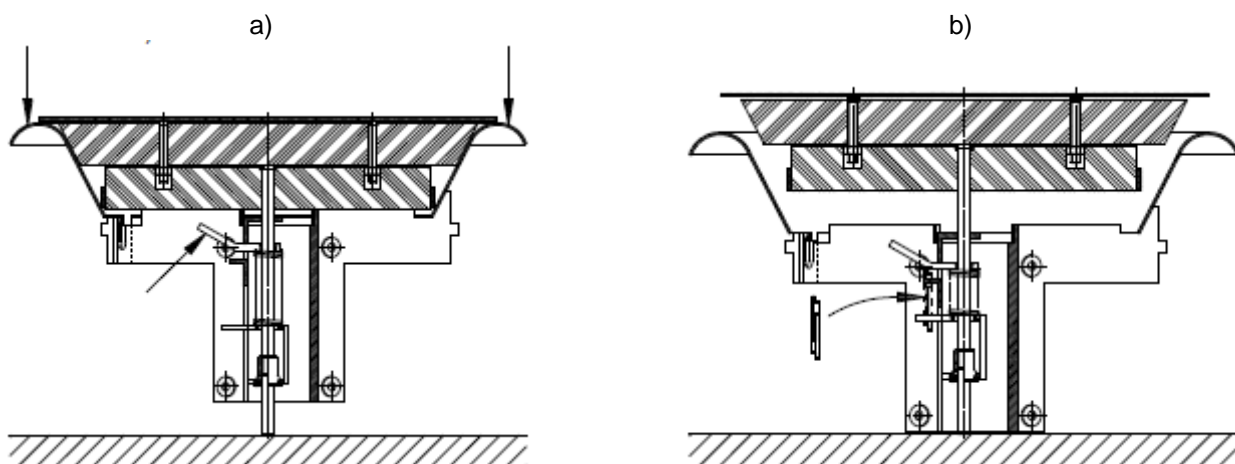

Figure 4. Arming the release and control mechanism:
a) points of applying the force; b) place of setting the thermal release.

mcr ZIPP fire protection shut-off valve

Before starting to arm the valve with the release and control mechanism of RST+EK type, make sure that the electromagnet operates correctly. In order to do so:

- plug the electrical wires into the terminal block (according to point 6.5.)
- **carefully clean the contact surfaces** and connect the plate with the electromagnet
- apply the signal that initialises the electromagnet release – supply voltage with the relevant value (after the initialising signal, the plate should detach from the electromagnet)

In order to arm the RST+EK release and control mechanism, the following actions have to be taken:

- screw the valve from the connection stub pipe
 - in the case of the RST+EKP mechanism (controlling via the "current gap"), plug all electric wires into the terminal block (in accordance with point 6.5.) and enable the electromagnet power supply.
 - in the case of the RST+EKI mechanism (controlling via the "current impulse"), plug all electric wires into the terminal block (in accordance with point 6.5.) and without enabling the electromagnet power supply.
- Connect the plate with the electromagnet
- rotate the valve so that the mushroom is on top
- simultaneously release the locking sheet and press the valve nozzle at its circumference (fig. 4a)
- push the fuse element onto the catches (fig. 2)

6.2. FIXING HOLE

Minimum diameter of the hole that allows correct installation of the mcr ZIPP valve equals:

- $D + 22$ – in the case of a wall made of plasterboards
- $D + 40$ – in the case of concrete, masonry and ceiling partitions

In rigid walls and ceiling

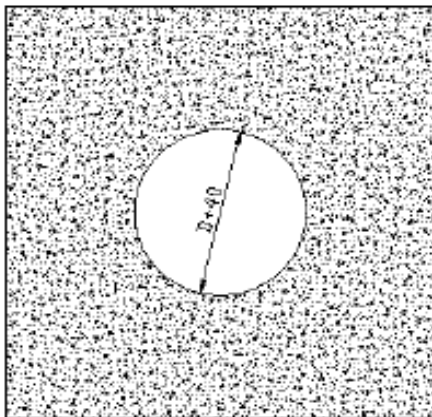

In light plasterboards walls

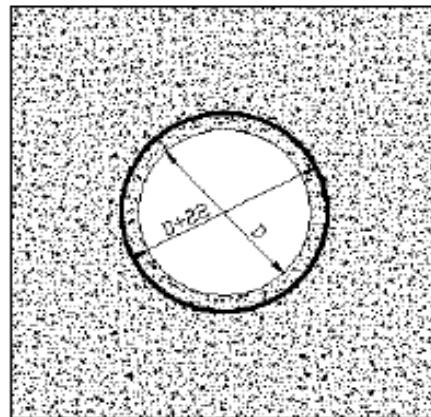

6.3. EMBEDDING / SETTING THE VALVE

INSTALLATION IN A CONCRETE OR MASONRY WALL

In the fixing hole, set the connection stub pipe with bent expansion sheets, so that the stub pipe axis is lined up with the hole axis. The gap between the stub pipe and the hole edge should be tightly packed with mortar or another material that provides the required fire resistance (fig. 5a). In case of installation through the wall to the duct, concurrently set the connection stub pipe and the extension stub pipe (figs 5b, 5c).

mcr ZIPP fire protection shut-off valve

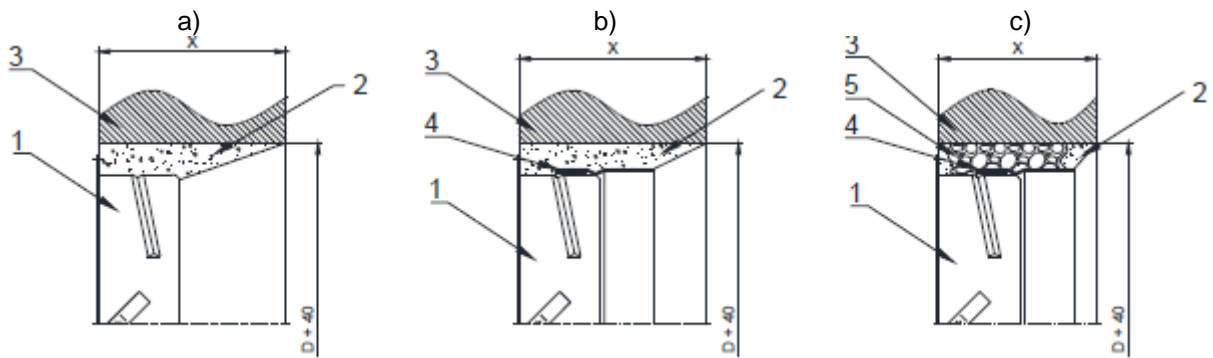

1- Connection stub pipe
2 – e.g. gypsum plaster or mortar

3 – Masonry or concrete wall
4 – Extension stub pipe

5 – Expanding polyurethane foam EI 120
X – wall thickness

Figure 5. Sample setting of a connection stub pipe in a masonry wall

NOTE

Pay particular attention to maintain the roundness of the connection stub pipe when filling the gap with mortar. Possible surfaces which are not round will make it impossible to set the valve.

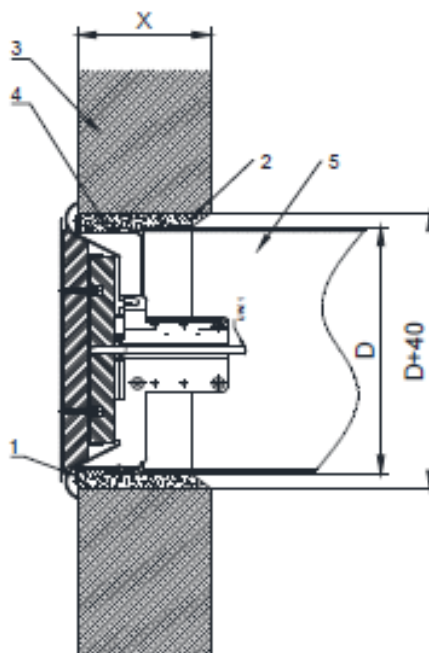

1- Connection stub pipe
2 – e.g. gypsum plaster or mortar

3 – Masonry or concrete wall
4 – Extension stub pipe

5 – ventilation duct
X – wall thickness

Figure 7. Sample installation of the mcr ZIPP valve in a concrete or masonry wall

INSTALLATION IN A PLASTERBOARD WALL

In the fixing hole, place the connection stub pipe with bent expansion sheets, so that the stub pipe axis is lined up with the hole axis. The gap between the stub pipe and the wall should be tightly filled with mortar, polyurethane foam EI 120 or gypsum (fig. 9a). In case of installation through the wall to the duct, concurrently set the connection stub pipe and the extension stub pipe (figs 9b, 9c).

mcr ZIPP fire protection shut-off valve

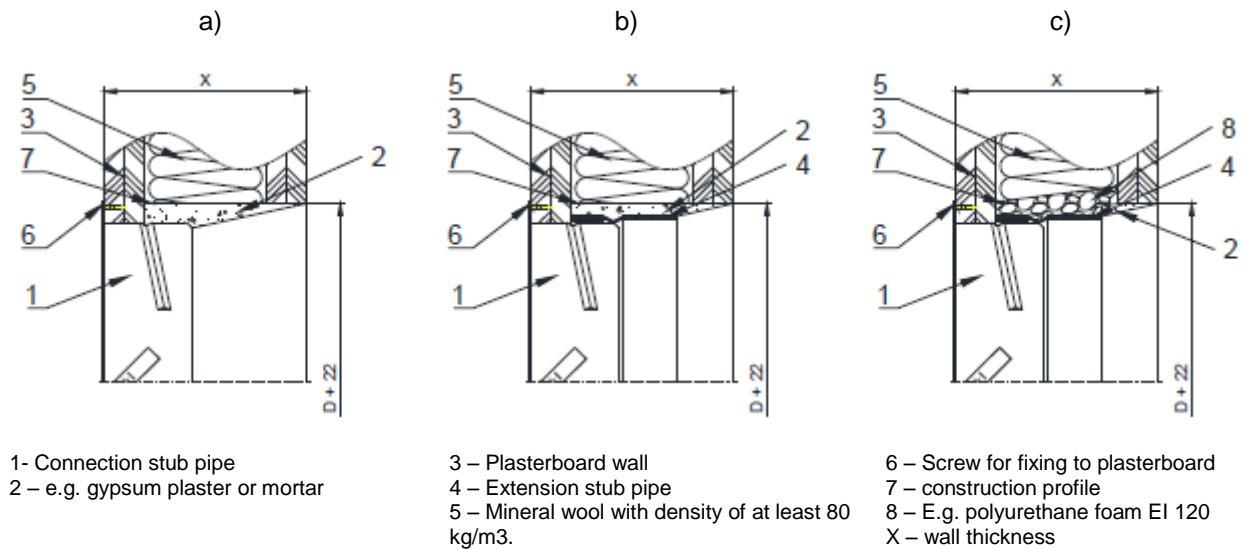

Figure 9. Sample setting of a connection stub pipe in a plasterboard wall

NOTE

Pay particular attention to maintain the roundness of the connection stub pipe when filling the gap with mortar. Possible surfaces which are not round will make it impossible to set the valve.

Set the prepared valve in the connection stub pipe. If it's possible to access the space between the nozzle and the stub pipe wall, it should be packed with mineral wool (fig. 10).

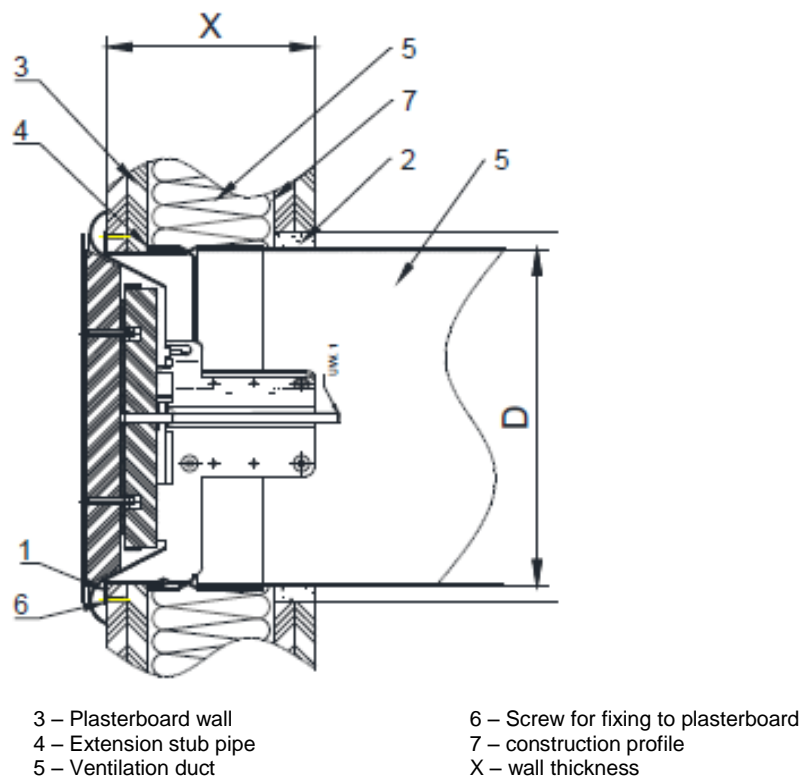
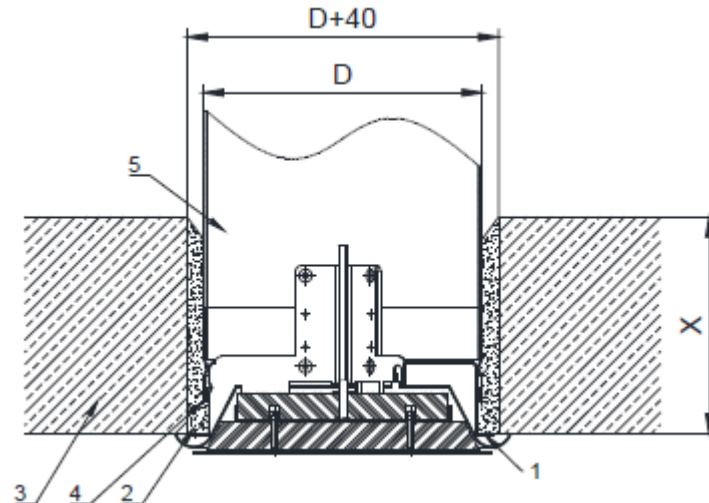

Figure 10. Sample installation of the mcr ZIPP valve in a plasterboard wall.

mcr ZIPP fire protection shut-off valve

INSTALLATION IN THE CEILING



- 1- Connection stub pipe
- 2 – e.g. gypsum plaster or mortar
- 3 – Concrete ceiling
- 4 – Extension stub pipe
- 5 – ventilation duct
- X – wall thickness

Figure 11. Sample method of installation for the mcr ZIPP valve in the ceiling

NOTE

During the installation of a mcr ZIPP, pay particular attention so that the thermal release (fuse element) do not get damaged, do not expose it to high temperature (fire, welders, soldering irons) that cause its activation (it is a single use element and is not subject to warranty replacement).

6.4. ELECTRICAL CONNECTIONS

Before the final setting of the valve in the connection stub pipe, connect the electrical lines for this system if there are any components that require such connection. Below you can see a connection method and the main data of the electrical components.

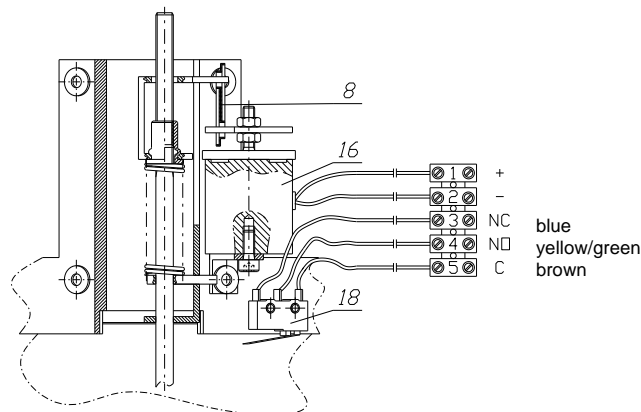

Figure 11. Connection of electrical components in a fire protection shut-off valve mcr ZIPP
(8 - Thermal release; 16 - Electromagnetic release; 18 - WK1 limit switch)

performance variant	RST	RST+K	RST+EKI	RST+EKP	MP230/24
thermal release	+	-	+	+	-
limit switch	-	250 V AC / 5 A	250 V AC / 5 A	250 V AC / 5 A	-
rated voltage			24 V DC	24 V DC	230 V AC /out. 24 V DC
power intake	-		3.5 W	1.8 W	2 W

Diagram of electrical connections for the
mcr ZIPP RST+WK1 valve

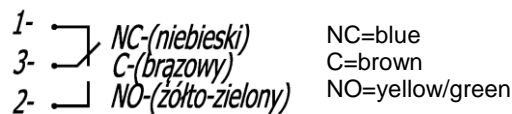
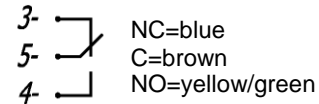

Diagram of electrical connections for the
mcr ZIPP RST+EK+WK1 valve

Power supply 24 V DC

1- "+"
2- "-"

Indication of closing



RST+EK release and control mechanism can cooperate with the MP230/24 module. In case of using the MP230/24 component, the valve can be supplied/controlled using 230 V AC voltage.

For proper operation of a device equipped with RST+EKI or RST+EKP mechanism, it is recommended that the rated voltage housed tolerance of $24V \pm 2\%$ or $230V \pm 2\%$. Power supply devices other than listed above may cause malfunction and will not be covered by the warranty conditions.

7. TRANSPORT AND STORAGE CONDITIONS

for the transport and storage, the fire protection shut-off valve, type mcr ZIPP is protected using bubble wrap and packaged in a cardboard box. Valve transport may take place using any means of transport, provided they are protected against weather factors. The valve should be protected against change of position during transport. After each transport, carry out visual inspection of each valve. Do not hit or drop the valve. The valve should be stored in closed rooms that provide protection against external weather conditions. In the case valves are stored on the ground, place them on protection pads in order to protect them against damage.

8. MAINTENANCE AND SERVICE

Mercor SA devices should undergo periodical technical inspections and maintenance actions, no less frequent than 12 months during the entire operation period, that is during the warranty period and after it. Inspections and maintenance should be carried out by the manufacturer or by companies that have authorisation for servicing of MERCOR SA devices.

The obligation to carry out regular service inspections of fire protection devices results from the Art. 3(3) of the Regulation by the Minister of Internal Affairs and Administration of 7 June 2010 on fire protection of buildings, other civil structures and areas (Journal of Laws 2010 No. 109, item 719).

It is recommended to execute, between inspections, the following:

- Inspections of the condition of electrical conditions, taking the mechanical damage particularly into account.
- Inspections of the condition of the supply voltage for the devices, which allowed the following tolerances:
 - $24V \pm 10\%$ for electric actuators
 - $24V \pm 2\%$ for electromagnetic release mechanism
 - $230V \pm 10\%$ for electric actuators
 - $230V \pm 2\%$ for electromagnetic release mechanism
- Inspections of the condition of the devices' body, taking the mechanical damage particularly into account.
- Checking whether there are no obstacles which could influence correct operation of the devices.

To enable the performance of actions included in the range of service inspections, as well as service and warranty actions such as visual inspections or repairs it is mandatory that the user provides the physical access to the devices, e.g. by disassembly of the thermal insulation, disassembly of suspended ceilings, disassembly of other systems if they prevent free access to the device etc.

In the case of devices installed in ducts, it is recommended to carry out the revisions, e.g. mcr KRW type.

If devices are installed on the roof, ensure the possibility to enter the roof (ladder or lift).

In the matters related with technical inspections, maintenance and the device service, contact the representatives of the Service Department of Mercor SA Serwis@mercor.com.pl, tel. 058/ 341 42 45 internal. 170 or fax 058/ 341 39 85 from 8 AM to 8 PM (Mon - Fri).

9. WARRANTY CONDITIONS

1. MERCOR SA issues a 12-month guarantee of quality for devices, counting from the date of purchase, unless the agreement states otherwise.
2. If, within the warranty period, physical defects of devices are found, MERCOR SA undertakes to remove them within the term no longer than 21 days counting from the date the written report is received and the purchase order or agreement is delivered, subject to point 6.
3. MERCOR SA reserves the right to prolong the repair time in the case of complex repairs or repairs that require the purchase of non-standards subassemblies or spare parts.
4. The warranty covers only the defects resulting from the sold devices.
5. In the case of defects resulting from incorrect operation of devices or from other causes indicated in point 6, the buyer / party entitled to the warranty will be charged with costs of removing it.
6. The warranty does not cover:
 - damage and faults of devices caused by incorrect operation, tampering by the user, lack of periodic technical inspections, non-performance of maintenance actions described in the part "SERVICE AND MAINTENANCE" of this document;
 - device damage resulting from causes other than the ones on the part of MERCOR SA, in particular: random events, specifically: torrential rain, flood, hurricane, inundation, lightning strike, overvoltage in the electrical network, explosion, hail, aircraft crash, fire, avalanche, landslide and secondary damage resulting from the abovementioned causes. Torrential rain is the rainfall intensity indicator of at least 4, set by the Institute of Meteorology and Water Management. In case setting the aforementioned indicator is impossible, the actual status and the extent of damage in the place they arise is taken into consideration to show the action of a torrential rain. A hurricane is a wind with speed no less than 17.5 m/s (damage is considered as caused by the hurricane if there is action of a hurricane in the nearest neighbourhood);
 - damage resulting from omission of the obligation to immediately report the found defect;
 - worsening the quality of coatings caused by their natural ageing processes;
 - defects caused by using abrasive or aggressive cleaning agents;
 - damage resulting from action of aggressive external factors, particularly chemical and biological, or which origin is related to manufacturing processes and actions carried out in the object or in its direct vicinity of the object where the devices are installed;
 - Parts that undergo natural wear during operation (e.g. gaskets), unless they show a factory defect;
 - damage resulting from incorrect transport, handling or storage of the device;
 - damage resulting from the assembly which is not compliant with the provisions of this Manual and the best construction practices;
 - devices or their parts in case the rating plate or warranty seals are damaged or removed.
7. A complaint application should be sent to MERCOR SA within 7 days from the date the defect covered by the warranty is found.
8. Complaint applications can be made under the phone number: 58/341-42-45, by fax: 58/341-39-85, by e-mail: reklamacje@mercor.com.pl or by sending the document to the address: MERCOR SA, ul. Grzegorza z Sanoka 2, 80-408 Gdańsk.
9. The Buyer / the party authorised for the warranty is obliged to correctly operate the devices and carry out the periodical technical inspections and maintenance actions, in accordance with the rules described in this document in the part "SERVICE AND MAINTENANCE" of this document.
10. The warranty expires immediately in case:
 - the Buyer / the party authorised for the warranty introduces construction changes within its own scope without prior agreement about this fact with MERCOR SA,
 - the periodic technical inspections and maintenance actions were not performed in time or were performed by unauthorised people or a service that did not have the MERCOR SA authorisation, or in the case the devices were operated incorrectly,
 - there was any tampering by unauthorised people, apart from actions included within normal operation of the devices.
11. In the cases specified in point 10, the liability of MERCOR SA for the warranty does not apply.
12. The condition of removing the defects is that the reporting party provides access to the full works front, particularly free access to rooms where the devices were installed and providing the necessary revisions, disassembly of thermal insulation, disassembly of suspended ceilings, disassembly of other systems if they prevent free access to the device etc.

To any matters unregulated herein, the applicable provisions of the Civil Code shall apply.