

UL-EU CERTIFICATE

Certificate No.
UL-EU-01129-EN

Issue date
2020-03-12

Issue No.
3

Re-Issue date
2026-02-16

Expiry date
2030-03-11



4705

This is to acknowledge that:
FSi Limited

Address:
Westminster Industrial Estate
Tamworth Road
Measham
DE12 7DS
United Kingdom

Has had the product:
PROMASTOP® - PenoPatch

evaluated and meets the requirements of the standards:

EAD 350454-00-1104, September 2017 / EN 13501-2

Places of production:
A/008

Authorised Signatory:

A blue ink handwritten signature, appearing to read 'Chris Johnson'.

Chris Johnson
Issued by UL International (UK) Ltd

This is to certify that representative samples of the Certified Product listed above have been investigated by Underwriters Laboratories to the Standard(s) indicated on this Certificate, in accordance with the UL Global Services Agreement and the UL-EU Mark Service Terms and Conditions ("Agreement"). The Certificate Holder is entitled to use the UL-EU Mark for the Certified Product listed on the certificate and manufactured at the production site(s) listed, in accordance with the terms of the Agreement. Only those products bearing the UL-EU Mark for Europe should be considered as being covered by UL's UL-EU Mark Service. This Certificate shall remain valid through the Expiration date, unless a Standard identified on this Certificate is amended or withdrawn prior to that date or there is a non-compliance with the Agreement.



Appendix UL-EU CERTIFICATE UL-EU-01129-EN

This certificate relates to the use of PROMASTOP® - PenoPatch for fire stopping where small cables, pipes or conduits penetrate flexible, masonry or concrete wall constructions. The detailed scope is given in pages 3 to 9 of this Certificate. This shows the thickness and acceptable dimensions, substrates and orientations required to provide fire resistance periods of up to 90 minutes (EI 90).

The product is certificated on the basis of:

- i) ETA 19/0833
- ii) EC – CERTIFICATE OF CONSTANCY OF PERFORMANCE 0843 – CPR – 0548
- ii) Inspection and surveillance of factory production control by UL
- iii) Fire resistance test data in accordance with 1366-3: 2009
- iv) Classification in accordance with EN 13501-2
- v) Durability and Serviceability as defined in EAD 350454-00-1104, September 2017

The durability class of PROMASTOP® - PenoPatch is Y₁ - Intended use at temperatures below 0°C, with exposure UV but no exposure to rain.

According to EN 1366-3: 2021+A1: 2024, Clause H.4.1.8.6.2, the following end uses are envisaged* based upon the tested pipe end configuration:

Pipe material	Tested pipe end	Envisaged use scenario
Metal	C/U or C/C	Closed pipe systems (e.g. systems under pressure)
	U/U, U/C or C/U	Ventilated pipe systems (e.g. sewage pipes) and for closed pipe systems
Plastic	U/U or C/U	Ventilated pipe systems and for closed pipe systems
	U/U	Ventilated pipe systems, for rainwater systems and for closed pipe systems

* In the case where a national prescription is in conflict with the content of the table above, the national prescriptions prevail.



Appendix UL-EU CERTIFICATE UL-EU-01129-EN

Product-type: Intumescent sheet		Intended use: Penetration Seal
Assessment method	Essential characteristic	Product performance
BWR 2 Safety in case of fire		
EN 13501-1	Reaction to fire	No performance determined
EN 13501-2	Resistance to fire	See pages 4 - 7
BWR 3 Hygiene, health and environment		
EN 1026	Air permeability	No performance determined
EAD 350454-00-1104, Annex C	Water permeability	No performance determined
Declaration of manufacturer & EN 16516	Content, emission and/or release of dangerous substances	Use categories: IA1 Declaration of manufacturer
BWR 4 Safety in use		
EOTA TR 001:2003	Mechanical resistance and stability	No performance determined
EOTA TR 001:2003	Resistance to impact/movement	No performance determined
EOTA TR 001:2003	Adhesion	No performance determined
EAD 350454-00-1104, Clause 2.2.9	Durability	Y ₁
BWR 5 Protection against noise		
EN 10140-1,2,4,5/ EN ISO 717-1	Airborne sound insulation	Rw(C;Ctr)= 67 (-1;-6) dB
BWR 6 Energy economy and heat retention		
EN 12664, EN 12667, EN 12939, EN ISO 8990, EN ISO 6946, EN ISO 14683, EN ISO 10211, EN ISO 10456	Thermal properties	No performance determined
EN ISO 12572, EN 12086, EN ISO 10456	Water vapour permeability	No performance determined



Appendix UL-EU CERTIFICATE UL-EU-01129-EN

Flexible or rigid wall constructions with wall thickness of minimum 75 mm

Cable, pipe or conduit penetration seals with 4 mm thick PROMASTOP® - PenoPatch

Penetration Seal: Small cables, pipes or conduits penetrating through a flexible or rigid wall construction and fitted at any position within the aperture, sealed with a 60 mm diameter PROMASTOP® - PenoPatch pad on both sides of the wall. Minimum separation between penetration seals 100 mm (a2).

Construction details:

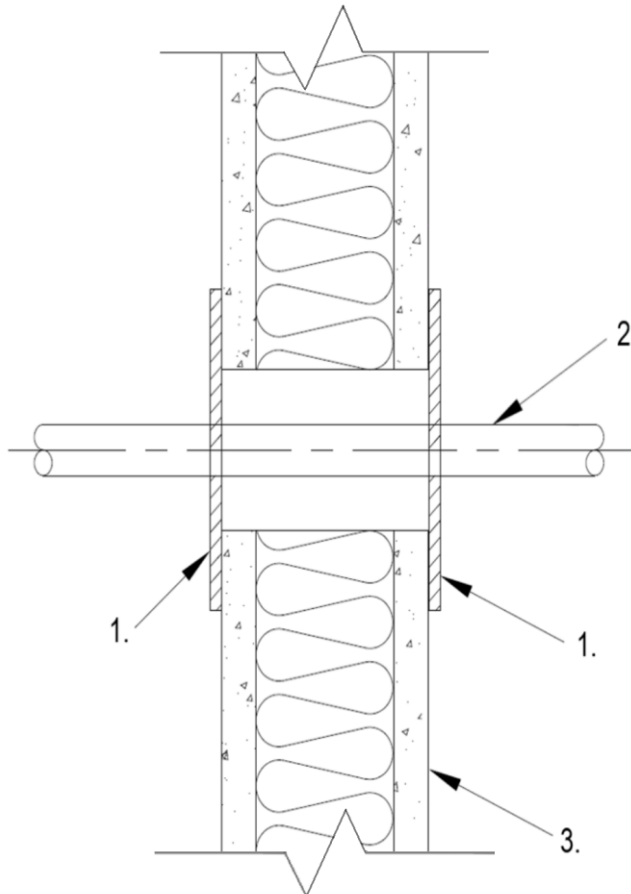

Key

1. 60 mm diameter PROMASTOP® - PenoPatch seal
2. Service
3. Flexible or rigid Wall ≥ 75 mm

Double side penetration seal

Services	PROMASTOP® - PenoPatch - mm	Aperture mm	Classification
Blank seal	60 mm Ø	25 mm wide x 25 mm high	EI 90
Single electric cables up to 21 mm diameter			EI 90
Single steel pipes up to 16 mm diameter			EI 90 U/U
Single PVC pipes up to 16 mm diameter			EI 90 C/C
Single 'E type' cable			EI 90



Solutions

Form-ULID-006104 V10.0

Appendix UL-EU CERTIFICATE UL-EU-01129-EN

Cable, pipe or conduit penetration seals with 4 mm thick PROMASTOP® - PenoPatch

Penetration Seal: Small cables, pipes or conduits penetrating through a flexible or rigid wall construction and fitted at any position within the aperture, sealed with a 100 mm diameter PROMASTOP® - PenoPatch pad on both sides of the wall. Minimum separation between penetration seals 100 mm (a2).

Construction details:

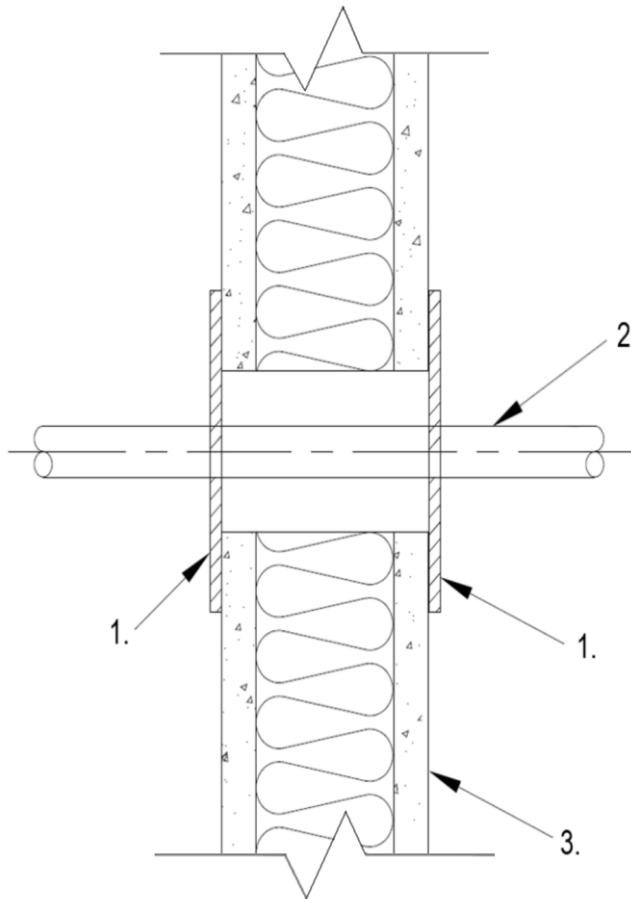

Key

1. 100 mm diameter PROMASTOP® - PenoPatch seal
2. Service
3. Flexible or rigid Wall ≥ 75 mm

Double side penetration seal

Services	PROMASTOP® - PenoPatch - mm	Aperture mm	Classification
Blank seal	100 mm \varnothing	50 mm wide x 50 mm high	EI 90
Single electric cables up to 21 mm diameter			E 60, EI 30
Single steel up to 16 mm diameter			E 90, EI 60 U/U
Single PVC pipes up to 16 mm diameter			EI 60 C/C
Single 'E type' cable			E 60, EI 45



Solutions

Form-ULID-006104 V10.0

Appendix UL-EU CERTIFICATE UL-EU-01129-EN

Flexible or rigid wall constructions with wall thickness of minimum 100 mm

Cable, pipe or conduit penetration seals with 4 mm thick PROMASTOP® - PenoPatch

Penetration Seal: Small cables, pipes or conduits penetrating through a flexible or rigid wall construction and fitted at any position within the aperture, sealed with a 60 mm diameter PROMASTOP® - PenoPatch pad on both sides of the wall. Minimum separation between penetration seals 5 mm (a2).

Construction details:

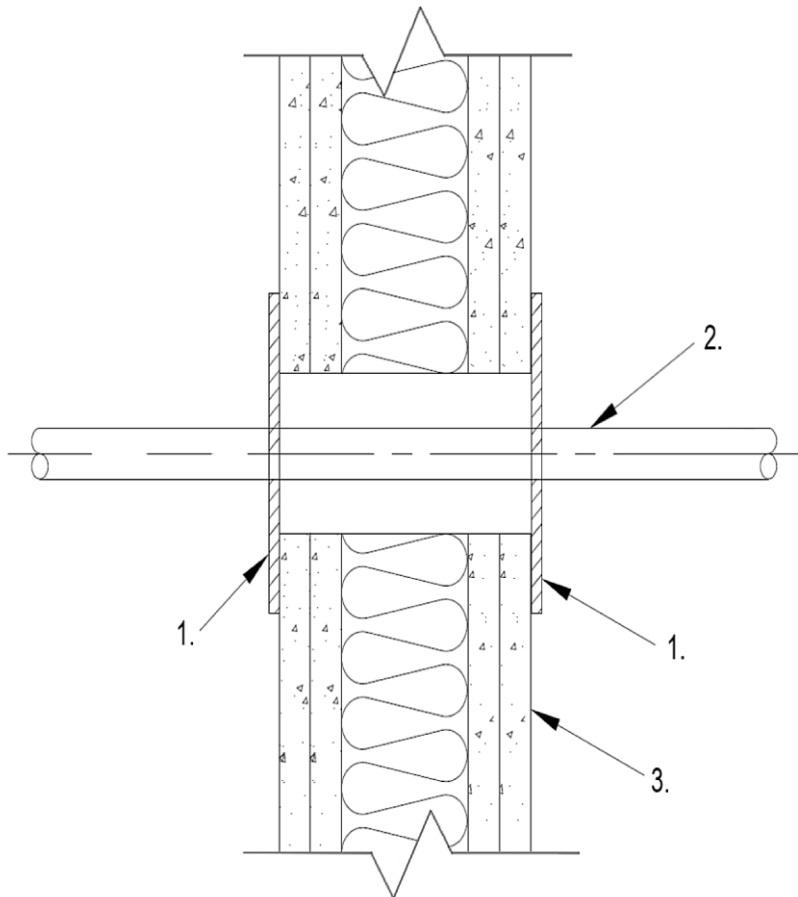

Key

1. 60 mm diameter PROMASTOP® - PenoPatch seal
2. Service
3. Flexible or rigid Wall ≥ 100 mm

Double side penetration seal

Services	PROMASTOP® - PenoPatch - mm	Aperture mm	Classification
Blank seal	60 mm Ø	25 mm wide x 25 mm high	EI 90
Single electric cables up to 21 mm diameter			EI 90
Electric cables up to 21 mm diameter			E 90, EI 45
Single steel pipes up to 16 mm diameter			EI 90 U/U
Single PVC pipes up to 16 mm diameter			EI 90 C/C
Single 'E type' cable			E 90, EI 30



Solutions

Form-ULID-006104 V10.0

Appendix UL-EU CERTIFICATE UL-EU-01129-EN

Cable, pipe or conduit penetration seals with 4 mm thick PROMASTOP® - PenoPatch

Penetration Seal: Small cables, pipes or conduits penetrating through a flexible or rigid wall construction and fitted at any position within the aperture, sealed with a 100 mm diameter PROMASTOP® - PenoPatch pad on both sides of the wall. Minimum separation between penetration seals 10 mm (a2).

Construction details:

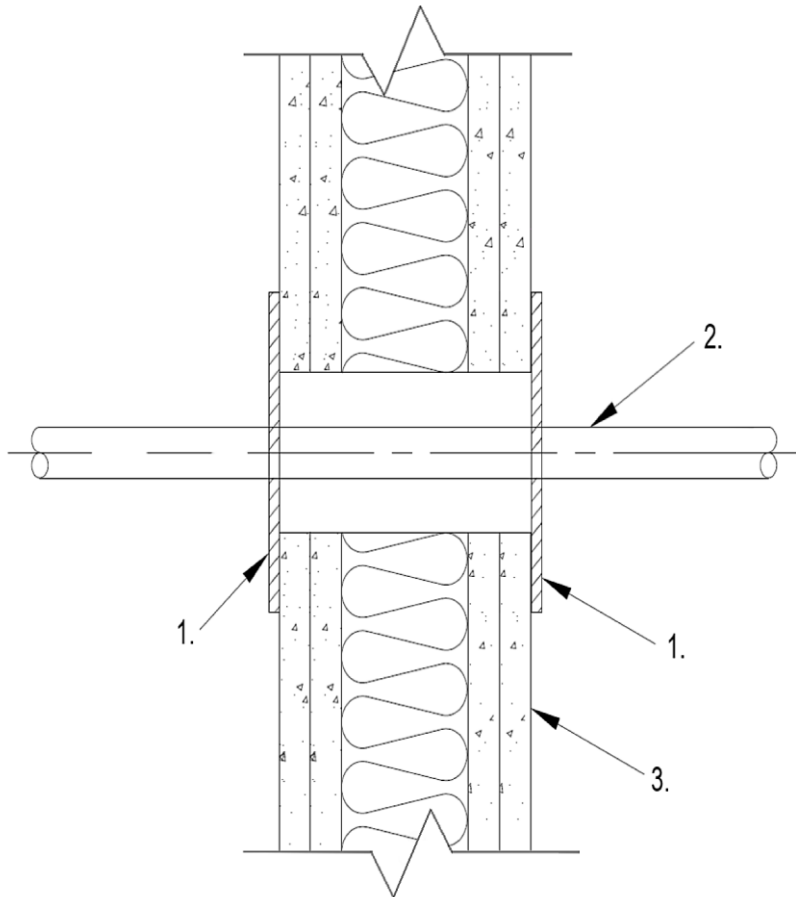

Key

1. 100 mm diameter PROMASTOP® - PenoPatch seal
2. Service
3. Flexible or rigid Wall \geq 100 mm

Double side penetration seal

Services	PROMASTOP® - PenoPatch - mm	Aperture mm	Classification
Blank seal	100 mm \emptyset	50 mm wide x 50 mm high	EI 90
Single or in bundle 'A1, A2 & A3 type' cables			E 90, EI 45
Electric cables up to 21 mm diameter			E 90, EI 30
Single steel up to 16 mm diameter			EI 90 U/U
Single PVC pipes up to 16 mm diameter			EI 90 C/C
Single 'E type' cable			E 90, EI 30
20mm plastic conduit with single 'B type' cable within			EI 90



Appendix UL-EU CERTIFICATE UL-EU-01129-EN

The UL-EU Marks, displayed below represent the enhanced and alternate version of the product marking. Either Mark can be used. These Marks shall appear on certified products only. Minimum size is not specified, as long as the Mark is legible. The following is suggested.



*Note: E12345 is an example of the UL file number.

The minimum height of the registered trademark symbol ® shall be 1 mm. When the overall diameter of the UL-EU Mark is less than 9.5 mm, the trademark symbol may be omitted if it is not legible to the naked eye.

The UL-EU Mark may appear on a label, nameplate, or may be cast, stamped or molded into the product. When appearing on a label or nameplate, the Manufacturer's name or trademark along with a model number and UL File number are also required on that same label or nameplate. If cast, stamped or molded, the Manufacturer's name or trademark and model number shall also appear elsewhere on the product.

All content shall be in accordance with the details provided on this UL-EU Certificate.

PROCUREMENT

The Production site may reproduce the Mark or obtain it from a UL authorized supplier. The list of UL authorized suppliers can be found on UL's online directory at www.ul.com.